

Bulletin No. BK4776-3 (04/2019)

**70 Series 8700 Washdown
2pc Hub & Shaft
3 Phase Brake Instructions
IP56 (NEMA 4X) Coupler Housing**

Read carefully before attempting to assemble, install, operate or maintain the product described. Protect yourself and others by observing all safety information. Failure to comply with instructions could result in personal injury and/or property damage! Retain instructions for future reference.

DESCRIPTION

These magnetic disc brakes mount directly onto NEMA182C, 213TC, and 256TC frame motors, on the drive shaft. The brake is direct acting, electro-magnetically released, and spring set. It uses rotating friction and stationary disc contact to supply positive braking and/or holding action. It retains quick release and setting capabilities at all times.

WARNING: Do not install or use these brakes in an explosive atmosphere.

WARNING: Brake performance and features must be carefully matched to the requirements of the application. Consideration must be given to torque requirements, especially where an overhauling condition exists, as well as thermal capacity, ambient temperature, atmospheric explosion hazards, type of enclosure and any other unusual conditions. Improper selection and installation of a brake and/or lack of maintenance may cause brake failure which could result in damage to property and/or injury to personnel. If injury to personnel could be caused by brake failure, additional means must be provided to insure safety of personnel.

UNPACKING

When unpacking the brake, inspect it carefully for damage that may have occurred during transit. Do not activate the manual release without the hub inserted in the discs as doing so may result in loss of disc spline alignment.

GENERAL SAFETY INFORMATION

NOTE: These brakes are not intended for accurate positioning applications. They are designed for applications that require rapid stopping and holding power, such as on conveyors, door openers, etc.

1. For applications with high inertia-type loads or rapid cycling, the thermal capacity of the brake must be considered.
2. Observe all local electrical and safety codes, as well as the National Electrical Code (NEC) & the Occupational Safety and Health Act (OSHA).
3. Brake motors & brake gearmotors must be securely & adequately grounded. This can be accomplished by wiring with a grounded metal-clad raceway system, by using a separate ground wire connected to the bare metal of the motor frame, or other suitable means. Refer to NEC Article 250 (Grounding) for additional information. All wiring should be done by a qualified electrician.
4. Always disconnect power before working on or near a brake motor, a brake gearmotor, or its connected load. If the power disconnect point is out of sight, lock it in the open position and tag it to prevent unexpected application of power.
5. When working on the brake, be sure the load is completely removed, secured or blocked to prevent injury or property damage.
6. Provide guarding for all moving parts.
7. Be careful when touching the exterior of an operating motor, gearmotor or brake. It may be hot enough to cause injury or to be painful. This condition is normal for modern motors, which operate at higher temperatures when running at rated load & voltage.
8. Protect all electrical lead wires & power cables against contact with sharp objects or moving parts.
9. Do not kink electrical lead wires & power cables, and never allow them to touch oil, grease, hot surfaces, or chemicals.

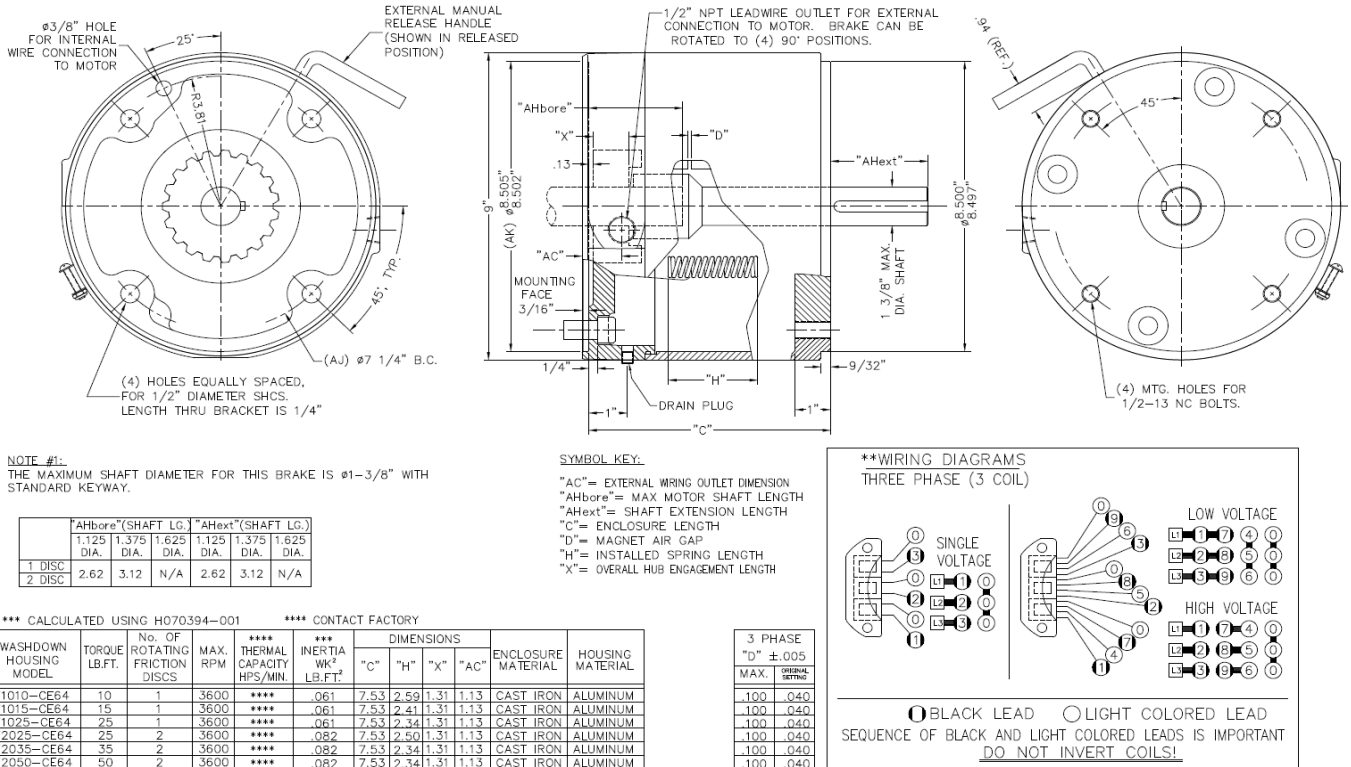

Figure 1 - Brake Outline

RECOMMENDED TOOLS AND HARDWARE

NOTE: The following tools and hardware are required for installing the brake onto a motor or mounting bracket. Use proper torque when required to ensure fasteners do not loosen during operation.

- 3/16 HEX BIT SOCKET (OR KEY)
- TORQUE WRENCH
- #2 PHILLIPS SCREWDRIVER
- 3/8 OPEN ENDED WRENCH OR SOCKET
- QUANTITY (4), 1/2 diameter SHCS, MINIMUM 1" LONG (see installation note #4 below)
- QUANTITY (4), 1/2-1/3 diameter SHCS, MINIMUM 1-1/2" LONG (see installation note #6 below)
- 3/8 EXTENDED LENGTH BALL END HEX SOCKET (OR T-HANDLE HEX KEY)

INSTALLATION (See Figures 1, & 2, Table 1)

1. Remove hub (99) from brake and position on motor shaft with key according to dimension "X"+.13" per figure 1. Stamped part number on hub should face away from motor. Tighten hub set screws with 18 lb.ft. torque.
2. Remove the wrap cover and hardware (80, 81 & 82) and set aside to expose the four access windows.
3. For IP56 (NEMA4) version, place gasket (91) onto motor side mounting face with mounting holes aligned.
4. Place brake on motor, guiding discs onto and through the hub. For IP56 (NEMA4) version, use caution not to pinch or damage the gasket (91).
5. Insert and install the 1/2 SHCS through the housing windows at four spots and secure and tighten each one to motor "C" face using an extended length ball end hex key brake. See Figure 1 to help in determining proper bolt length. Final bolt thread pitch, length and mounting torque is dependent on the material and depth of the threaded holes in the mounting face.
6. Line up and insert the shaft end of the brake/motor combination into the gear box or transmission component "C" face flange and align the hole set for the flange and the brake.
7. Insert and install the 1/2-13 SHCS through the gear box flange and into the brake housing. Final bolt length and mounting torque is dependent on the material and thickness of the gear box mounting flange.
8. Reinstall wrap cover and hardware. Make sure the seam if the wrap cover is not over an access window opening.
9. Connect coil leads per appropriate wiring diagram in Figure 1.

REPLACEMENT PARTS LIST

(See Figure 2)

ITEM NO.	DESCRIPTION	MODEL						PART NO.
		Nema 4X 2 Piece Shaft Coupler						
		71010-CE64	71015-CE64	71025-CE64	72025-CE64	72035-CE64	72050-CE64	
1	Bracket assembly, 1&2 disc	1	1	1	1	1	1	K070582-023
7	Handle, manual release	1	1	1	1	1	1	H070422-002
11	Spring, return manual release	1	1	1	1	1	1	G070846-001
12	Cam, manual release	1	1	1	1	1	1	H070393-001
13	Screw, retaining, cam	1	1	1	1	1	1	W001045-043
17	Post, pivot	1	1	1	1	1	1	W002005-168A
19	Stud post, magnet assembly/cover	2	2	2	2	2	2	H070395-001
20	Stud Post, Coupler	2	2	2	2	2	2	H070407-001
25	Disc, rotating friction	1	1	1	2	2	2	H070394-001
26	Disc, stationary	1	1	1	2	2	2	K070560-001
27	Spring, pivot	1	1	1	1	1	1	G070847-001
28	Bolt, torque spring	2	2	2	2	2	2	W001007-069
32	Pressure plate assembly, three phase	1	1	1	1	1	1	H070423-001
37	Bushing, flanged	3	3	3	3	3	3	W013007-061
42	Spring, torque, silver			2			2	G070848-001
42	Spring, torque, gold	2	2		2	2		G070849-001
43	Washer, flat	3	3	3	3	3	3	W004021-081
44	Nut, adjustment	3	3	3	3	3	3	W003013-005
46	Washer, magnet assembly base	2	2	2	2	2	2	W004004-018
50A	Magnet Assembly, three phase	1	1	1	1	1	1	H070403-XXX
50	Magnet frame, three phase	1	1	1	1	1	1	K070568-001
51	Coil, Magnet, three phase	1	1	1	1	1	1	H020003-XXX
54	Clamp, cable	1	1	1	1	1	1	W021008-005
55	Screw, cable clamp	1	1	1	1	1	1	W001038-143
59	Washer, shock absorber	2	2	2	2	2	2	G070850-001
60	Washer, capture	2	2	2	2	2	2	W004004-017
61	Nut, nylock magnet assembly	2	2	2	2	2	2	W003013-010
65	O-ring, Bracket/Cover	1	1	1	1	1	1	W006001-036
67	Housing, Coupler, 6207 Bearing	1	1	1	1	1	1	L070521-003
67	Housing, Coupler, 6209 Bearing	1	1	1	1	1	1	L070522-003
68	Bearing, Ball, 6207	1	1	1	1	1	1	W009001-003
68	Bearing, Ball, 6209	1	1	1	1	1	1	W009001-019
69	Retaining Ring, Housing, 6207 Bearing	1	1	1	1	1	1	W006002-003
69	Retaining Ring, Housing, 6209 Bearing	1	1	1	1	1	1	W006002-004
71	Nut, cover	4	4	4	4	4	4	W003001-020
75	Hub & Shaft, Coupler 1&2D	1	1	1	1	1	1	PER ORDER
76	Retaining Ring, Shaft, 6207 Bearing	1	1	1	1	1	1	W006003-003
76	Retaining Ring, Shaft, 6209 Bearing	1	1	1	1	1	1	W006003-010
80	Wrap Cover, Stainless steel	1	1	1	1	1	1	K070576-003
81	Screw, Wrap Cover	2	2	2	2	2	2	W001051-126
82	Nut, Wrap Cover	2	2	2	2	2	2	W003021-008
84	Nameplate	1	1	1	1	1	1	K060467-001
85	Screw, nameplate	2	2	2	2	2	2	W001012-048
86	Release label	1	1	1	1	1	1	G070860-001
87	Pipe plug, 1/2	1	1	1	1	1	1	W010002-004
88	Pipe plug, 1/8	1	1	1	1	1	1	W010002-001
91	Bracket gasket	1	1	1	1	1	1	K070250-004
92	Cap plug 1/2	1	1	1	1	1	1	W008006-004
93	Cap plug 1/4	1	1	1	1	1	1	W008006-001
94	Bissc sticker	1	1	1	1	1	1	G060763-002
99	Hub Assembly, 1 & 2 Disc	1	1	1	1	1	1	H070431-XXX
99	Hub Assembly, 1 & 2 Disc (optional)	1	1	1	1	1	1	H070432-XXX

XXX-Figure per model number

Table 1 - Parts List

EXPLODED VIEW

(See Table 1)

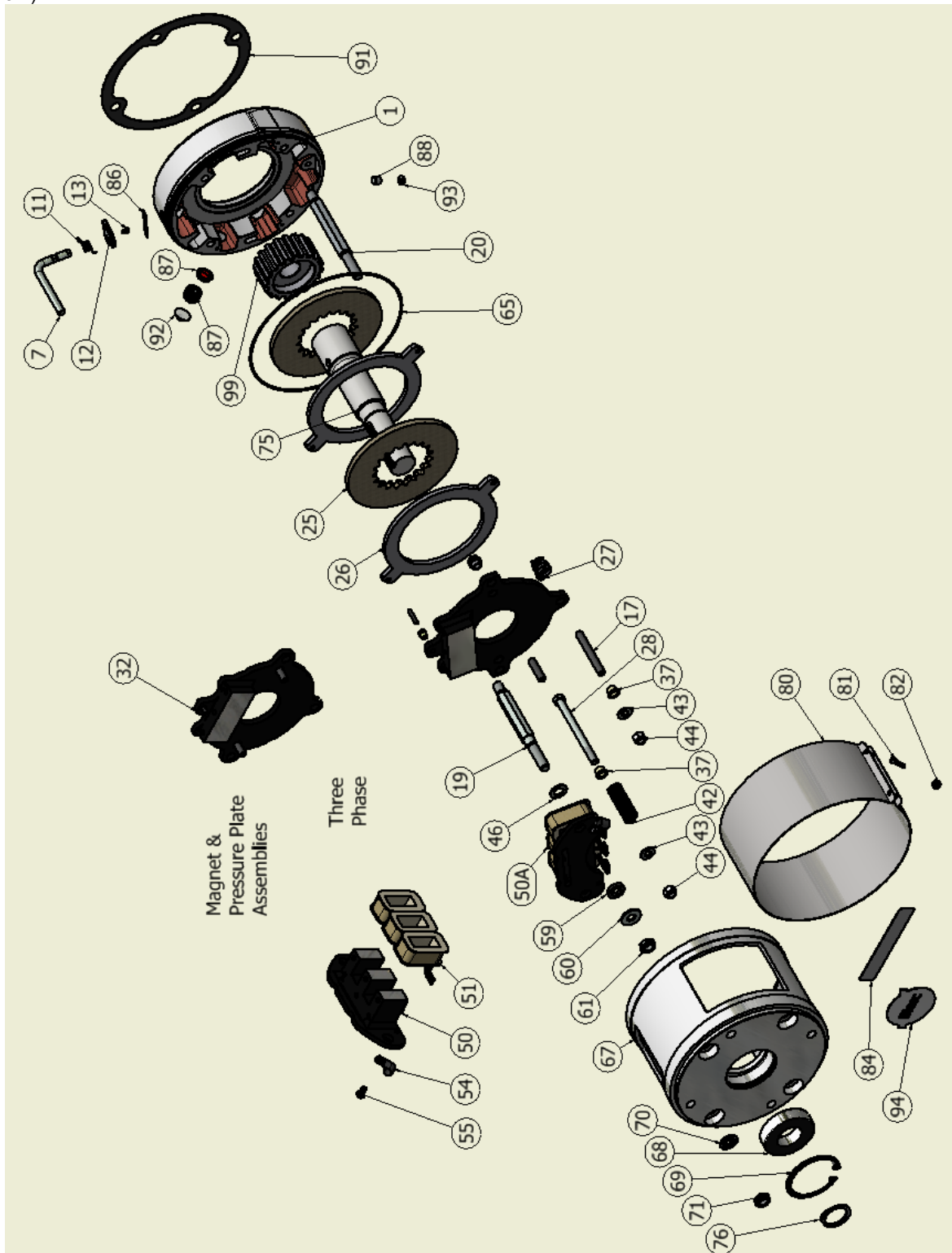

Figure 2 - Exploded View of Brake