



80 Series 4 Post NEMA 2 Enclosure Brake Instructions

Read carefully before attempting to assemble, install, operate or maintain the product described. Protect yourself and others by observing all safety information. Failure to comply with instructions could result in personal injury and/or property damage! Retain instructions for future reference. When unpacking the brake, inspect it carefully for damage that may have occurred during transit.



Figure 1.

WARNING

Brake performance and features must be carefully matched to the requirements of the application.

Consideration must be given to torque requirements, especially where an overhauling condition exists, as well as thermal capacity, ambient temperature, atmospheric explosion hazards, type of enclosure and any other unusual conditions.

Improper selection and installation of a brake and/or lack of maintenance may cause brake failure which could result in damage to property and/or injury to personnel.

If injury to personnel could be caused by brake failure, additional means must be provided to insure safety of personnel.

Do not operate manual release or energize brake coil before installation, in order to preserve prealignment of rotating discs for ease of installation.

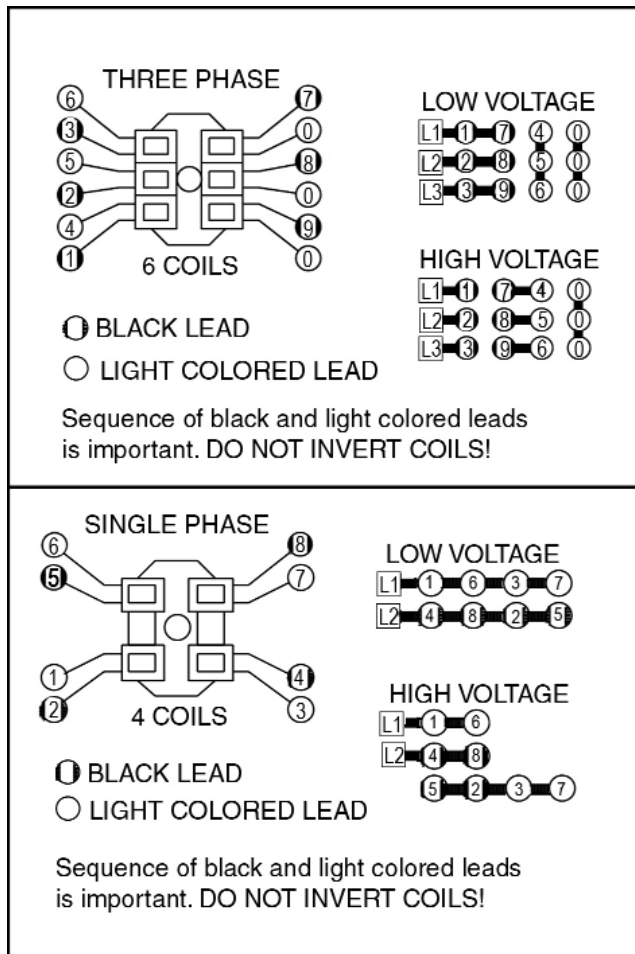

Figure 2. Wiring Diagram

DESCRIPTION

This brake is direct acting, electromagnetically released and spring set. It uses rotating and stationary disc contact to supply positive braking action. It retains quick release and setting capabilities at all times.

Simplicity of design has reduced maintenance to an absolute minimum. As with any electromechanical equipment, however, periodic inspection and adjustment will assure optimum performance. As the friction disc wears, the magnet gap will increase. The magnet gap should be checked periodically and adjusted when necessary.

SPECIFICATIONS

MOTOR FRAMES - 284TC, 286TC.

HOUSINGS - Cast iron and aluminum.

DUTY - Rated for continuous duty.

VOLTAGES - All standard NEMA voltages and frequencies available. Other voltages and frequencies are optional.

MOUNTING - Direct to NEMA "C" motor flanges. Adaptors for larger or smaller frames, foot mounting and vertical mounting are available.

SHAFTS - NEMA standard length motor shafts and thru shafts may be used on all models except units with Mark II Release (Cover modification required for thru shafts).

ORDERING INFORMATION

The following data should be furnished with your order for:

REPLACEMENT PARTS

Brake Model Number

Part Number from Tables

Part Description from Tables

(On hub order furnish bore dia. & keyway dimensions. On electrical parts specify voltage, phase & frequency.)

REPLACEMENT BRAKE

Model Number

Voltage, Phase & Frequency

Hub Bore & Keyway Dimensions

Mounting - Horizontal or Vertical. (If vertical, specify whether above or below motor. If brake includes foot mounting bracket or adaptor, specify.)

G080341-001

INSTALLATION

(See Figures 3, 5 & 6, Tables 1, 2 & 3)

1. Remove hub (1) from brake and position on motor shaft with key according to dimension "N". Stamped part number on hub should face away from motor. Tighten hub set screws with 12 lb. ft. torque.
2. Remove cover screws (24) and cover (23).
3. Place brake on motor, guiding discs on hub.
4. Bolt brake to motor "C" face with four 1/2 inch socket head cap screws. See Figures 5 and 6 for screw length thru bracket.
5. Connect coil leads per appropriate wiring diagram in Figure 2 and replace cover.

MANUAL RELEASE

(See Figure 3)

To operate release, rotate two rods(10) clockwise until stop screw (14) hits pin. Brake will remain in released position until rods are manually returned to original position, or until electrical power is restored which automatically returns the release rods to the set position.

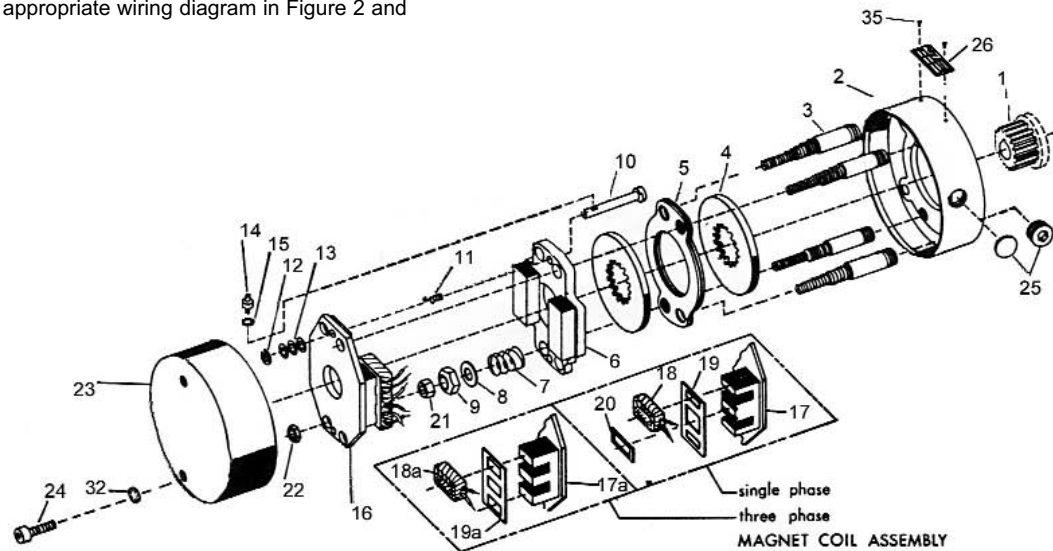

Figure 3. Exploded View of Brake

TORQUE ADJUSTMENT

(See Figures 3 & 5)

Brake is factory set for rated torque per spring length "H". To increase stopping time and lower torque, turn four locknuts (9) counterclockwise, increasing dimension "H". All four springs must be set to the same length. Do not decrease spring length "H" as this may cause coil to burn out.

WEAR ADJUSTMENT

(See Figures 3 & 5, Table 2)

Magnet gap "D" increases as friction discs wear. When gap approaches "D" max., adjust gap to "D" min. dimension by turning nuts (21 and 22). Magnet gap can vary from nominal $\pm .005$ " between corners. After setting gap, readjust torque spring length "H".

CAUTION: MAGNET GAP MUST NOT EXCEED "D" MAXIMUM.

FRICION DISC REPLACEMENT

(See Figures 3 & 5, Table 2)

*When the rotating friction disc (4) wears down to a thickness of 7/32", replace disc.

1. Remove cover screws (24) and cover (23).
2. Unhook loop of torsion springs (11) from pins at rear of magnet plate (16). Remove release stop screws (14), washers (12) and shims (13).
3. Remove adjusting lock nuts (22), magnet assembly (16), adjusting nuts (21), torque nuts (9), washers (8), torque spring (7) and pressure plate (6).
4. Remove friction disc (4) and stationary disc (5). Replace worn friction discs.
5. Reassemble all parts in reverse order. Set spring length "H" and magnet gap "D". Assemble manual release. See following paragraph.

MANUAL RELEASE ASSEMBLY

(See Figure 3)

When assembling a standard manual release mechanism (Figure 3), add only enough shim washers (13) to obtain proper release action. Too many shim washers will prevent automatic reset when electrical power is applied. Too few washers will prevent the motor shaft from turning freely. Replace stop screws (14). Wind each torsion spring (11) approximately 1/4 turn and hook spring loop over pin.

MAGNET COIL REPLACEMENT

(See Figures 3 & 4)

Remove magnet assembly as outlined under FRICTION DISC REPLACEMENT.

Coils (18) are held in place with epoxy cement. Force coil off magnet mounting plate and remove excess epoxy from all surfaces.

Replacement coils should be held in place with new epoxy cement. The epoxy cement should be heat resistant and shock resistant. Place an insulating washer (19 or 19a) below the coils. Order insulating washers when ordering coils. An insulating washer can be cut to suit when replacing only one coil on a multiple coil assembly.

When installing coils, it is very important to follow EXACTLY the sequence of black and light colored leads as shown in wiring diagram (Figure 2). The brake will not operate properly unless coils are all in the correct position.

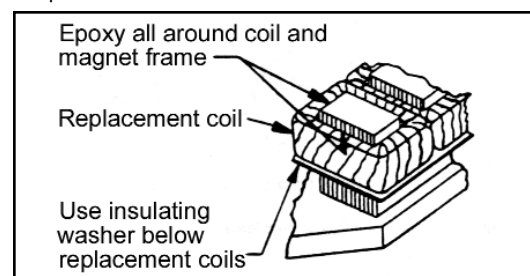

Figure 4. Fastening of Replacement Magnet Coils

Table 1. Parts List

ITEM NO.	PCS. REQ'D	DESCRIPTION	PART NO.
1	1	Hub	H08003* (4)
2	1	Bracket w/studs – 1 disc	H080309-001
2	1	Bracket w/studs – 2 disc	H080309-002
2	1	Bracket w/studs – 3 disc	H080309-003
2	1	Bracket w/studs – 4 disc	H080309-004
2	1	Bracket w/studs – 5 disc	H080309-005
2a	1	Bracket w/high tensile studs – 1 disc	H080309-006
2a	1	Bracket w/high tensile studs – 2 disc	H080309-007
2a	1	Bracket w/high tensile studs – 3 disc	H080309-008
2a	1	Bracket w/high tensile studs – 4 disc	H080309-009
2a	1	Bracket w/high tensile studs – 5 disc	H080309-010
3	4	Stud – 1 disc	G070213-001
3	4	Stud – 2 disc	G070213-002
3	4	Stud – 3 disc	G070213-003
3	4	Stud – 4 disc	G070213-004
3	4	Stud – 5 disc	G070213-005
3a	4	Stud – 1 disc high tensile	G070219-001
3a	4	Stud – 2 disc high tensile	G070219-002
3a	4	Stud – 3 disc high tensile	G070219-003
3a	4	Stud – 4 disc high tensile	G070219-004
3a	4	Stud – 5 disc high tensile	G070219-005
4	Note (1)	Rotating friction disc	H080002-004
4a	Note (1)	Heavy duty rotating friction disc (Alt.)	K080281-001
5	Note (2)	Stationary disc	K080282-002
6	1	Pressure plate	K080072-001
7	4	Torque spring (25, 50, 75 lb-ft)	G070011-001
7	4	Torque spring (35, 70, 105, 125 175 lb-ft)	G070019-001
8	4	Torque spring washer	W004004-001
9	4	Torque adjusting nut	W003001-022
10	2	Manual release rod	G070001-002
11	2	Manual release spring	G060010-001
12	2	Manual release washer	W004004-003
13	As Req'd	Manual release shim	W004004-004
14	2	Manual release stop screw	G060029-001
15	2	Manual release lockwasher	W004007-007
16	1	Magnet assembly, single phase – complete with coils	K080126 (3)
16	1	Magnet assembly, three phase – complete with coils	K080127 (3)
17	1	Magnet plate w/o coils, single phase	K080152-001
17a	1	Magnet plate w/o coils, three phase	K080101-001
18	4	Magnet coil – single phase	K080083 (3)
18a	6	Magnet coil – three phase	H080062 (3)
19	2	Insulating washer – single phase	G080148-001
19a	2	Insulating washer – three phase	G080016-001
20	2	Shading coil, single phase only	G080022-001
21	4	Gap adjusting nut	W003003-023
22	4	Gap adjusting nut	W003001-020
23	1	Cover, standard	K080287-002
24	2	Cover screw	W001002-103
25	1	Conduit hole plug	W008001-007
26	1	Nameplate	K060473-001
32	2	Lockwasher, 1/4	W004008-006
35	2	Drive screw	W001012-048

(1) Number of rotating discs is shown as second digit of Model No.

Example: 2-82050-28

(2) Number of stationary discs is one less than the number of rotating discs.

(3) Basic part number shown—specify model number, voltage, phase and frequency.

(4) Basic part number shown—specify shaft diameter.

Table 2. Dimensions

Torque lb-ft	Model No.	Wt. Lbs.	Thermal Capacity HPS/Min	Inertia WK ² lb-ft ²	Dimensions in inches						
					C	N	X	AC	D		H
									MAX	MIN	
25	6-81025-58	57	15	0.084	6.25	1.75	1.00	1.73	.065	.035	1.31
35	6-81035-58	57	15	0.084	6.25	1.75	1.00	1.73	.065	.035	1.31
50	6-82050-58	65	17	0.158	6.87	2.25	1.50	2.35	.065	.035	1.31
70	6-82070-58	65	17	0.158	6.87	2.25	1.50	2.35	.065	.035	1.31
75	6-83075-58	70	19	0.233	7.50	2.75	2.00	2.98	.070	.040	1.31
105	6-83105-58	70	19	0.233	7.50	2.75	2.00	2.98	.070	.040	1.31
125	6-84125-58	75	21	0.307	8.12	3.25	2.50	3.60	.080	.050	1.43
175	6-85175-58	81	21	0.384	8.75	3.87	3.12	4.23	.080	.050	1.31

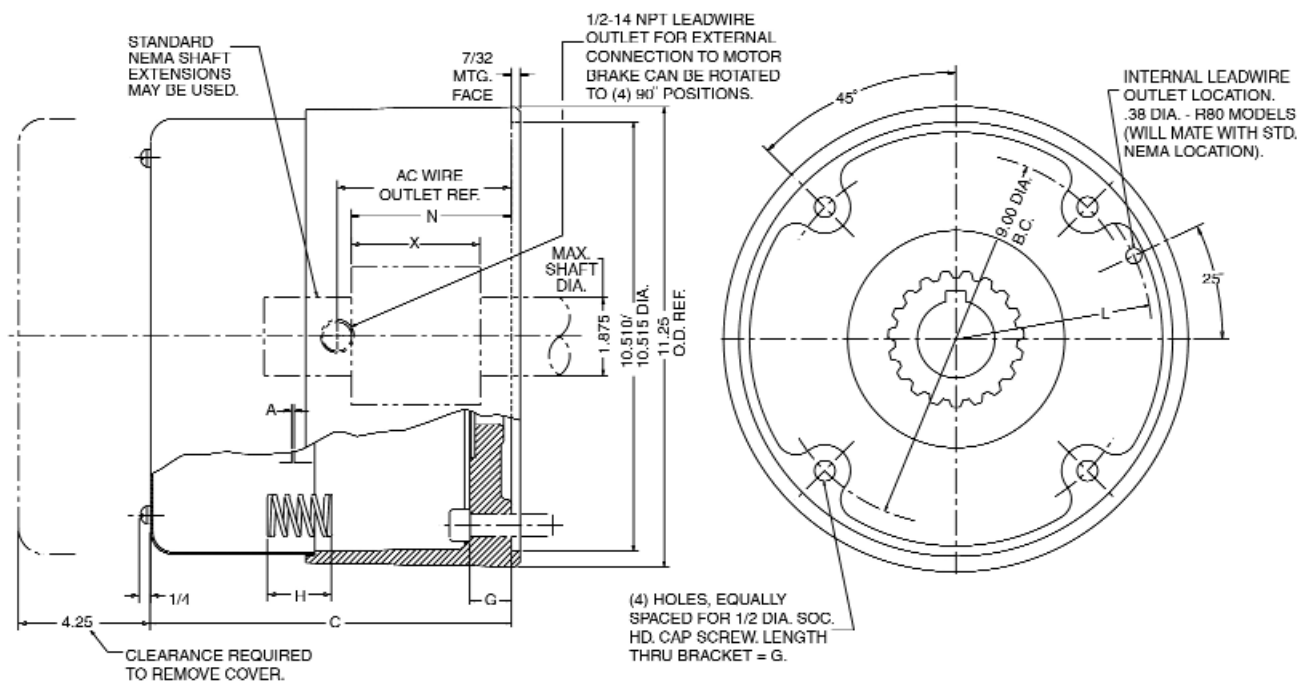

Figure 5. Outline Drawing

TROUBLE SHOOTING

A. IF BRAKE DOES NOT RELEASE:

1. Check brake visually for broken or damaged parts.
2. Check for broken leadwire or bad electrical connection.
3. Check for correct voltage. Line voltage must correspond to the voltage for which the brake coils are connected. If the line voltage is more than 10% below the voltage for which the brake coils are connected, the magnet will not pull in, causing the coils to burn out within minutes. If the line voltage is more than 10% above the voltage for which the brake coils are connected, the coils will overheat and burn out.
4. Check for burned-out coils (coils may be charred or burned).
5. Check for excessive magnet gap. (See WEAR ADJUSTMENT.)
6. Check for failure or power supply to brake.

B. IF BRAKE DOES NOT STOP:

1. Check brake visually for broken or damaged parts.
2. Make certain hub has not shifted position on the motor shaft and that all rotating discs are fully engaged on the hub.
3. Check that the manual release is in the normal position.
4. Check disc wear. (See WEAR ADJUSTMENT.)

C. IF BRAKE CHATTERS OR HUMS:

1. See that magnet faces are clean. To remove dirt, insert a clean sheet of paper between magnet faces and energize brake. Move paper around between faces to dislodge dirt, then remove paper.
2. Check for low voltage. Magnet will not pull in, and coils will burn out if line voltage is beyond 10% below the voltage the brake coils are connected for.
3. See that magnet faces are parallel within tolerance. Readjust magnet gap to "D" min. (See WEAR ADJUSTMENT.)
4. Check if shading coil (20) is cracked, broken or out of position (single phase only).

D. IF MANUAL RELEASE DOES NOT WORK:

1. Check for broken or damaged parts.
2. Check return spring (11). Brake will not reset automatically if this spring is broken.
3. Check quantity of shim washers (13) under release stop screws. (See MANUAL RELEASE ASSEMBLY.)

