

EXTERNAL MANUAL RELEASE HANDLE (SHOWN IN RELEASED POSITION)

$1/2$ " NPT LEADWIRE OUTLET FOR EXTERNAL CONNECTION TO MOTOR. BRAKE CAN BE ROTATED TO (4) 90° POSITIONS.

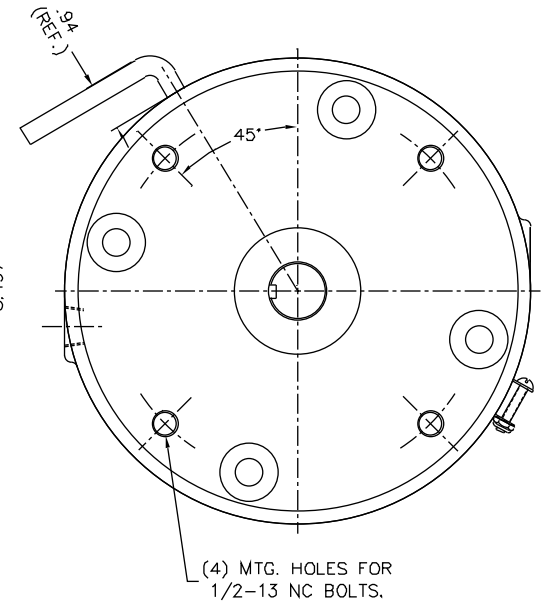
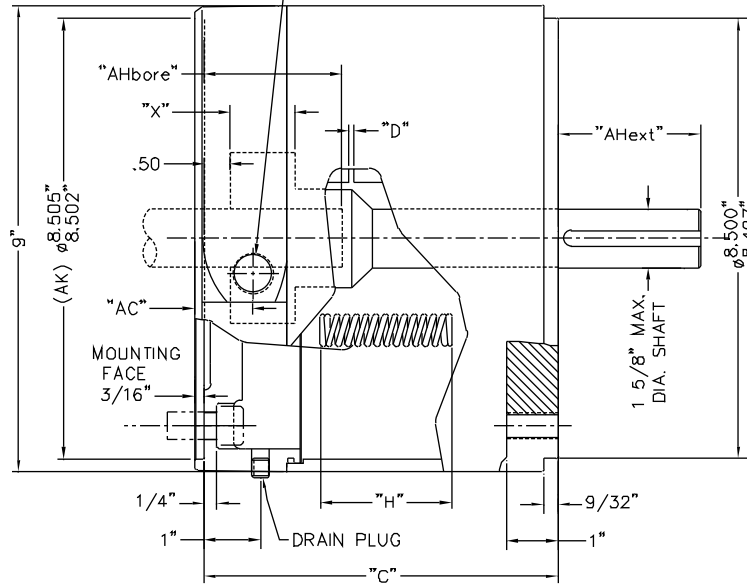

	"AHbore"(SHAFT LG.)			"AHext"(SHAFT LG.)		
	1.125 DIA.	1.375 DIA.	1.625 DIA.	1.125 DIA.	1.375 DIA.	1.625 DIA.
1 DISC						
2 DISC	2.62	3.12	N/A	2.62	3.12	3.75
3 DISC						
4 DISC			3.75			

NOTE #1:
THE MAXIMUM SHAFT DIAMETER FOR THIS BRAKE IS $\phi 1-5/8$ " WITH STANDARD KEYWAY.

SYMBOL KEY:

"AC"= EXTERNAL WIRING OUTLET DIMENSION
 "AHbore"= MAX MOTOR SHAFT LENGTH
 "AHext"= SHAFT EXTENSION LENGTH
 "C"= ENCLOSURE LENGTH
 "D"= MAGNET AIR GAP
 "H"= INSTALLED SPRING LENGTH
 "X"= OVERALL HUB LENGTH

*** CALCULATED USING H070394-001

**** CONTACT FACTORY

ENCLOSED HOUSING MODEL	TORQUE LB.FT.	No. OF ROTATING FRICTION DISCS	MAX. RPM	**** THERMAL CAPACITY HPS/MIN.	*** INERTIA WK ² LB.FT.	DIMENSIONS				ENCLOSURE MATERIAL	HOUSING MATERIAL
						"c"	"H"	"X"	"AC"		
71010-CE63	10	1	3600	****	.055	7.53	2.59	1.25	1.13	CAST IRON	ALUMINUM
71015-CE63	15	1	3600	****	.055	7.53	2.41	1.25	1.13	CAST IRON	ALUMINUM
71025-CE63	25	1	3600	****	.055	7.53	2.34	1.25	1.13	CAST IRON	ALUMINUM
72025-CE63	25	2	3600	****	.076	7.53	2.50	1.25	1.13	CAST IRON	ALUMINUM
72035-CE63	35	2	3600	****	.076	7.53	2.34	1.25	1.13	CAST IRON	ALUMINUM
72050-CE63	50	2	3600	****	.076	7.53	2.34	1.25	1.13	CAST IRON	ALUMINUM
73050-CE63	50	3	3600	****	.108	8.10	2.34	1.81	1.69	CAST IRON	ALUMINUM
74050-CE63	50	4	3600	****	.145	8.66	2.50	2.38	2.25	CAST IRON	ALUMINUM
73075-CE63	75	3	3600	****	.108	8.10	2.34	1.81	1.69	CAST IRON	ALUMINUM
74075-CE63	75	4	3600	****	.145	8.66	2.28	2.38	2.25	CAST IRON	ALUMINUM
74105-CE63	105	4	3600	****	.145	8.66	2.31	2.38	2.25	CAST IRON	ALUMINUM

1 PHASE "D" $\pm .005$		3 PHASE "D" $\pm .005$	
MAX.	ORIGINAL SETTING	MAX.	ORIGINAL SETTING
.125	.075	.100	.040
.125	.075	.100	.040

