



## 70 Series 8700 End-Mount 1 Phase Brake Instructions IP56 (NEMA 4) Housing

**Read carefully before attempting to assemble, install, operate or maintain the product described. Protect yourself and others by observing all safety information. Failure to comply with instructions could result in personal injury and/or property damage! Retain instructions for future reference.**

### **DESCRIPTION**

These magnetic disc brakes mount directly onto NEMA182C, 213TC, and 256TC frame motors, on the end opposite the drive shaft. The brake is direct acting, electro-magnetically released, and spring set. It uses rotating friction and stationary disc contact to supply positive braking action. It retains quick release and setting capabilities at all times.

**WARNING: Do not install or use these brakes in an explosive atmosphere.**

**WARNING: Brake performance and features must be carefully matched to the requirements of the application. Consideration must be given to torque requirements, especially where an overhauling condition exists, as well as thermal capacity, ambient temperature, atmospheric explosion hazards, type of enclosure and any other unusual conditions. Improper selection and installation of a brake and/or lack of maintenance may cause brake failure which could result in damage to property and/or injury to personnel. If injury to personnel could be caused by brake failure, additional means must be provided to insure safety of personnel.**

### **UNPACKING**

When unpacking the brake, inspect it carefully for damage that may have occurred during transit. Do not activate the manual release without the hub inserted in the discs as doing so may result in loss of disc spline alignment.

### **GENERAL SAFETY INFORMATION**

**NOTE:** These brakes are not intended for accurate positioning applications. They are designed for applications that require rapid stopping and holding power, such as on conveyors, door openers, etc.

1. For applications with high inertia-type loads or rapid cycling, the thermal capacity of the brake must be considered.
2. Observe all local electrical and safety codes, as well as the National Electrical Code (NEC) & the Occupational Safety and Health Act (OSHA).
3. Brake motors & brake gearmotors must be securely & adequately grounded. This can be accomplished by wiring with a grounded metal-clad raceway system, by using a separate ground wire connected to the bare metal of the motor frame, or other suitable means. Refer to NEC Article 250 (Grounding) for additional information. All wiring should be done by a qualified electrician.
4. Always disconnect power before working on or near a brake motor, a brake gearmotor, or its connected load. If the power disconnect point is out of sight, lock it in the open position and tag it to prevent unexpected application of power.
5. When working on the brake, be sure the load is completely removed, secured or blocked to prevent injury or property damage.
6. Provide guarding for all moving parts.
7. Be careful when touching the exterior of an operating motor, gearmotor or brake. It may be hot enough to cause injury or to be painful. This condition is normal for modern motors, which operate at higher temperatures when running at rated load & voltage.
8. Protect all electrical lead wires & power cables against contact with sharp objects or moving parts.
9. Do not kink electrical lead wires & power cables, and never allow them to touch oil, grease, hot surfaces, or chemicals.

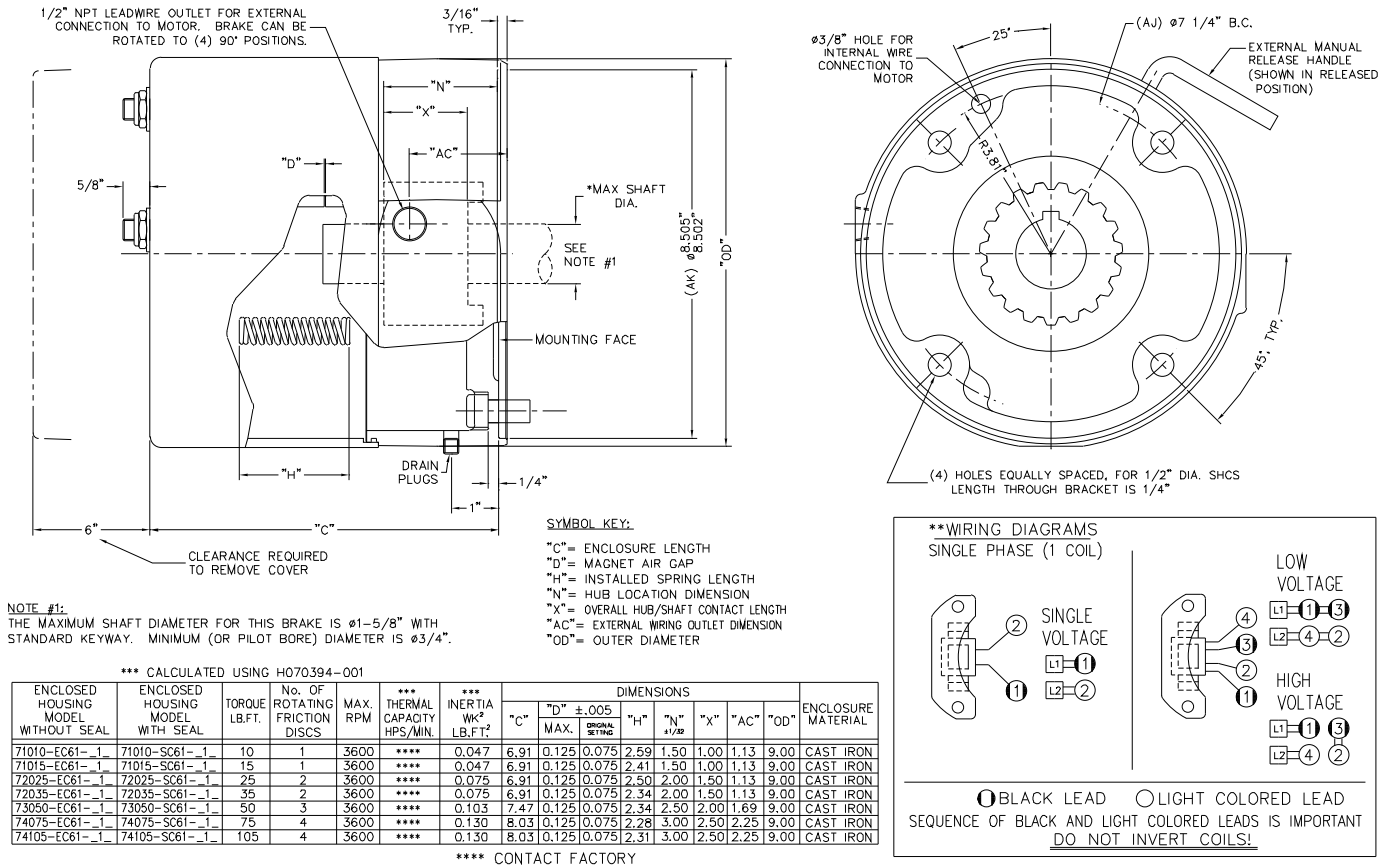

Figure.1 Brake Outline

## RECOMMENDED TOOLS AND HARDWARE

NOTE: The following tools and hardware are required for installing the brake onto a motor or mounting bracket. Use proper torque when required to ensure fasteners do not loosen during operation.

- 3/4 INCH HEX WRENCH OR RATCHET/SOCKET
- 5/32 HEX BIT SOCKET (OR KEY)
- TORQUE WRENCH
- QUANTITY (4), 1/2 diameter SHCS, MINIMUM 1" LONG (see installation note #5 below)
- 3/8 BALL END HEX BIT SOCKET (KEY OR T-HANDLE)

## INSTALLATION

(See Figures 1, & 2, Table 1)

1. Remove hub (99) from brake and position on motor shaft with key according to dimension "N" per figure 1. Stamped part number on hub should face away from motor. Tighten hub set screws with 13 lb.ft. torque.
2. Remove temporary cover nut and cover (67). Set cover aside. Discard temporary nut.
3. If brake is supplied with a mounting face gasket (91), place gasket onto the brake mounting face.
4. Place brake on motor, guiding discs on hub. Use caution not to pinch gasket. For horizontal mounted brakes, the drain plug should be pointed down.
5. Bolt brake to motor "C" face with four socket head cap screws. See Figure 1 to help in determining proper bolt length. Final bolt thread pitch, length and mounting torque is dependent on the material and depth of the threaded holes in the mounting face.
6. Connect coil leads per appropriate wiring diagram in Figure 1 and replace cover (67).
7. Use provided sealing washers (70) and nylon locking nuts (71) to secure cover (67).

**REPLACEMENT PARTS LIST**

(See Figure 2)

ITEM NO.	DESCRIPTION	MODEL														PART NO.		
		Endmount <b>without</b> Hub Seal							Endmount <b>with</b> Hub Seal									
		71010-EC61	71015-EC61	72025-EC61	72035-EC61	73050-EC61	74075-EC61	74105-EC61	74125-EC61	71010-SC61	71015-SC61	72025-SC61	72035-SC61	73050-SC61	74075-SC61		74105-SC61	74125-SC61
1	Bracket assembly, 1&2 disc	1	1	1	1					1	1	1	1					K070579-XXX
1	Bracket assembly, 1&2 disc with hub seal									1	1	1	1					K070579-XXX
1	Bracket assembly, 3 disc					1												K070580-XXX
1	Bracket assembly, 3 disc with hub seal												1					K070580-XXX
1	Bracket assembly, 4 disc						1	1	1									K070581-XXX
1	Bracket assembly, 4 disc with hub seal													1	1	1		K070581-XXX
7	Handle, manual release	1	1	1	1	1	1	1	1	1	1	1	1	1	1	1	1	H070422-002
11	Spring, return manual release	1	1	1	1	1	1	1	1	1	1	1	1	1	1	1	1	G070846-001
12	Cam, manual release	1	1	1	1	1	1	1	1	1	1	1	1	1	1	1	1	H070393-001
13	Screw, retaining, cam	1	1	1	1	1	1	1	1	1	1	1	1	1	1	1	1	W001045-043
17	Post, pivot	1	1	1	1	1	1	1	1	1	1	1	1	1	1	1	1	W002005-168
19	Stud post, magnet assembly/cover	2	2	2	2	2	2	2	2	2	2	2	2	2	2	2	2	H070395-001
25	Disc, rotating friction	1	1	2	2	3	4	4	4	1	1	2	2	3	4	4	4	H070394-001
26	Disc, stationary	1	1	2	2	3	4	4	4	1	1	2	2	3	4	4	4	K070560-001
27	Spring, pivot	1	1	1	1	1	1	1	1	1	1	1	1	1	1	1	1	G070847-001
28	Bolt, torque spring	2	2	2	2	2	2	2	2	2	2	2	2	2	2	2	2	W001007-069
32	Pressure plate assembly, single phase	1	1	1	1	1	1	1	1	1	1	1	1	1	1	1	1	H070424-001
37	Bushing, flanged	3	3	3	3	3	3	3	3	3	3	3	3	3	3	3	3	W013007-061
42	Spring, torque, silver							2	2							2	2	G070848-001
42	Spring, torque, gold	2	2	2	2	2	2	2	2	2	2	2	2	2	2	2	2	G070849-001
43	Washer, flat	3	3	3	3	3	3	3	3	3	3	3	3	3	3	3	3	W004002-008
44	Nut, adjustment	3	3	3	3	3	3	3	3	3	3	3	3	3	3	3	3	W003013-005
46	Washer, magnet assembly base	2	2	2	2	2	2	2	2	2	2	2	2	2	2	2	2	W004004-018
50A	Magnet Assembly, single phase	1	1	1	1	1	1	1	1	1	1	1	1	1	1	1	1	H070405-XXX
50	Magnet frame, single phase	1	1	1	1	1	1	1	1	1	1	1	1	1	1	1	1	K070569-001
51	Coil, magnet, single phase	1	1	1	1	1	1	1	1	1	1	1	1	1	1	1	1	H070013-XXX
54	Clamp, cable	1	1	1	1	1	1	1	1	1	1	1	1	1	1	1	1	W021008-005
55	Screw, cable clamp	1	1	1	1	1	1	1	1	1	1	1	1	1	1	1	1	W001038-143
59	Washer, shock absorber	2	2	2	2	2	2	2	2	2	2	2	2	2	2	2	2	G070850-001
60	Washer, capture	2	2	2	2	2	2	2	2	2	2	2	2	2	2	2	2	W004004-017
61	Nut, nylock magnet assembly	2	2	2	2	2	2	2	2	2	2	2	2	2	2	2	2	W003001-20
65	O-ring, bracket/cover	1	1	1	1	1	1	1	1	1	1	1	1	1	1	1	1	W006001-036
67	Cover, cast iron	1	1	1	1	1	1	1	1	1	1	1	1	1	1	1	1	K070554-001
70	Sealing washer	2	2	2	2	2	2	2	2	2	2	2	2	2	2	2	2	W011002-010
71	Nut, cover	2	2	2	2	2	2	2	2	2	2	2	2	2	2	2	2	W003001-020
84	Nameplate, metal	1	1	1	1	1	1	1	1	1	1	1	1	1	1	1	1	K070574-001
85	Drive screw	2	2	2	2	2	2	2	2	2	2	2	2	2	2	2	2	W001012-048
86	Release label	1	1	1	1	1	1	1	1	1	1	1	1	1	1	1	1	G070852-001
87	Capplug, 1/2 NPT									1	1	1	1	1	1	1	1	W008003-001
87	Pipe plug, 1/2	1	1	1	1	1	1	1	1									W010002-004
88	Pipe plug, 1/8	1	1	1	1	1	1	1	1	1	1	1	1	1	1	1	1	W010002-004
91	Bracket gasket	1	1	1	1	1	1	1	1									K070250-005
99	Hub assembly 1 disc	1	1															H080030-XXX
99	Hub assembly 2 disc			1	1													H080031-XXX
99	Hub assembly 3 disc					1												H080032-XXX
99	Hub assembly 4 disc						1	1	1									H080033-XXX
99	Hub assembly 1 disc w/seal									1	1							H070408-XXX
99	Hub assembly 2 disc w/seal										1	1						H070411-XXX
99	Hub assembly 3 disc w/seal												1					H070416-XXX
99	Hub assembly 4 disc w/seal														1	1	1	H070419-XXX

XXX-Figure per model number

Table 1 - Parts List

## **EXPLODED VIEW**

(See Table 1)

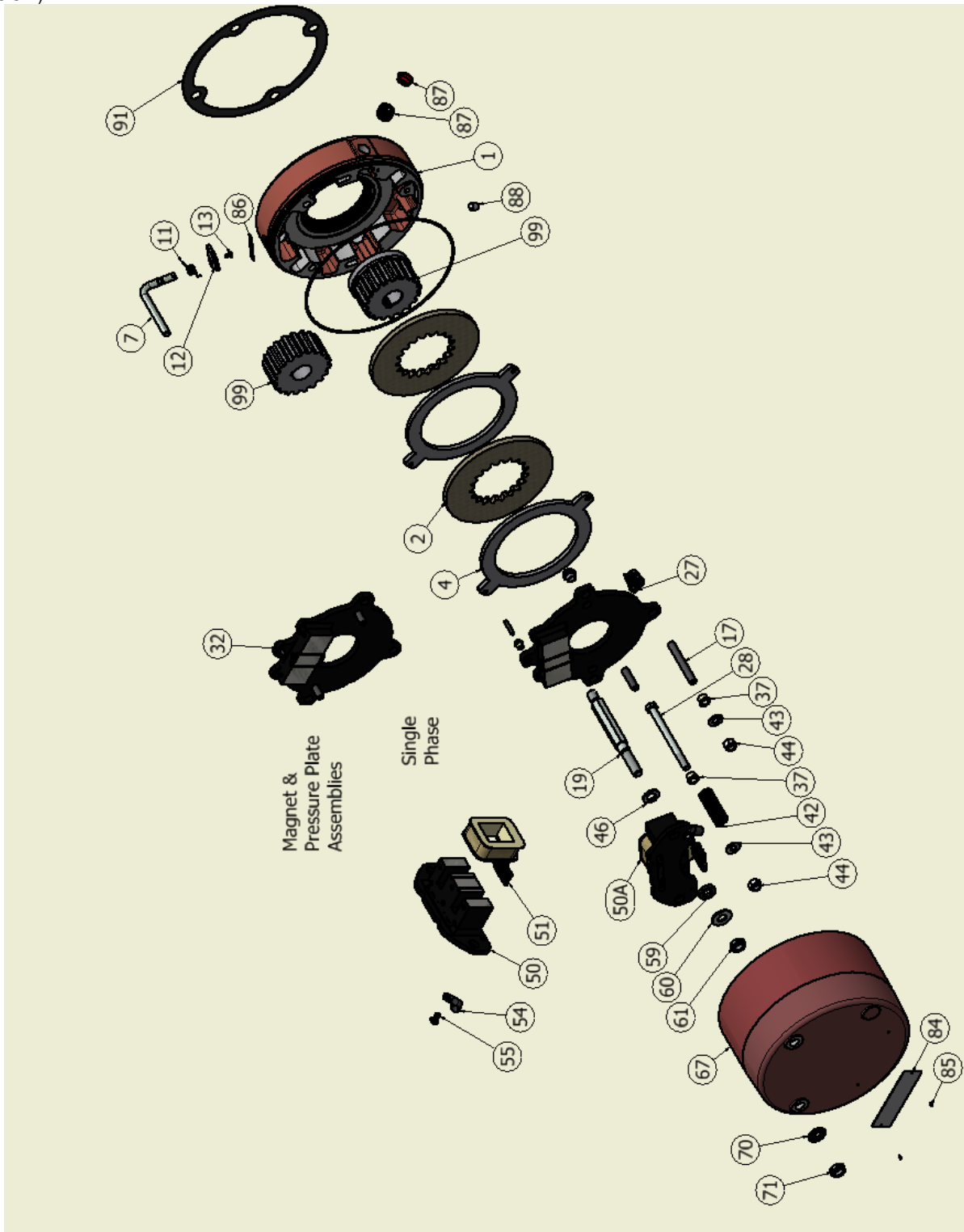

Figure 2 - Exploded View of Brake