



**70 Series 8700 End Mount
Three Phase Brake Instructions
IP43 (NEMA 2) Housing**



Read carefully before attempting to assemble, install, operate or maintain the product described. Protect yourself and others by observing all safety information. Failure to comply with instructions could result in personal injury and/or property damage! Retain instructions for future reference.

DESCRIPTION

These magnetic disc brakes mount directly onto NEMA182TC, 213TC, and 256TC frame motors, on the end opposite the drive shaft. The brake is direct acting, electro-magnetically released, and spring set. It uses rotating friction and stationary disc contact to supply positive braking action. It retains quick release and setting capabilities at all times.

WARNING: Do not install or use these brakes in an explosive atmosphere.

WARNING: Brake performance and features must be carefully matched to the requirements of the application. Consideration must be given to torque requirements, especially where an overhauling condition exists, as well as thermal capacity, ambient temperature, atmospheric explosion hazards, type of enclosure and any other unusual conditions. Improper selection and installation of a brake and/or lack of maintenance may cause brake failure which could result in damage to property and/or injury to personnel. If injury to personnel could be caused by brake failure, additional means must be provided to insure safety of personnel.

UNPACKING

When unpacking the brake, inspect it carefully for damage that may have occurred during transit. Do not activate the manual release without the hub inserted in the discs as doing so may result in loss of disc spline alignment.

GENERAL SAFETY INFORMATION

NOTE: These brakes are not intended for accurate positioning applications. They are designed for applications that require rapid stopping and holding power, such as on conveyors, door openers, etc.

1. For applications with high inertia-type loads or rapid cycling, the thermal capacity of the brake must be considered.
2. Observe all local electrical and safety codes, as well as the National Electrical Code (NEC) & the Occupational Safety and Health Act (OSHA).
3. Brake motors & brake gearmotors must be securely & adequately grounded. This can be accomplished by wiring with a grounded metal-clad raceway system, by using a separate ground wire connected to the bare metal of the motor frame, or other suitable means. Refer to NEC Article 250 (Grounding) for additional information. All wiring should be done by a qualified electrician.
4. Always disconnect power before working on or near a brake motor, a brake gearmotor, or its connected load. If the power disconnect point is out of sight, lock it in the open position and tag it to prevent unexpected application of power.
5. When working on the brake, be sure the load is completely removed, secured or blocked to prevent injury or property damage.
6. Provide guarding for all moving parts.
7. Be careful when touching the exterior of an operating motor, gearmotor or brake. It may be hot enough to cause injury or to be painful. This condition is normal for modern motors, which operate at higher temperatures when running at rated load & voltage.
8. Protect all electrical lead wires & power cables against contact with sharp objects or moving parts.
9. Do not kink electrical lead wires & power cables, and never allow them to touch oil, grease, hot surfaces, or chemicals.

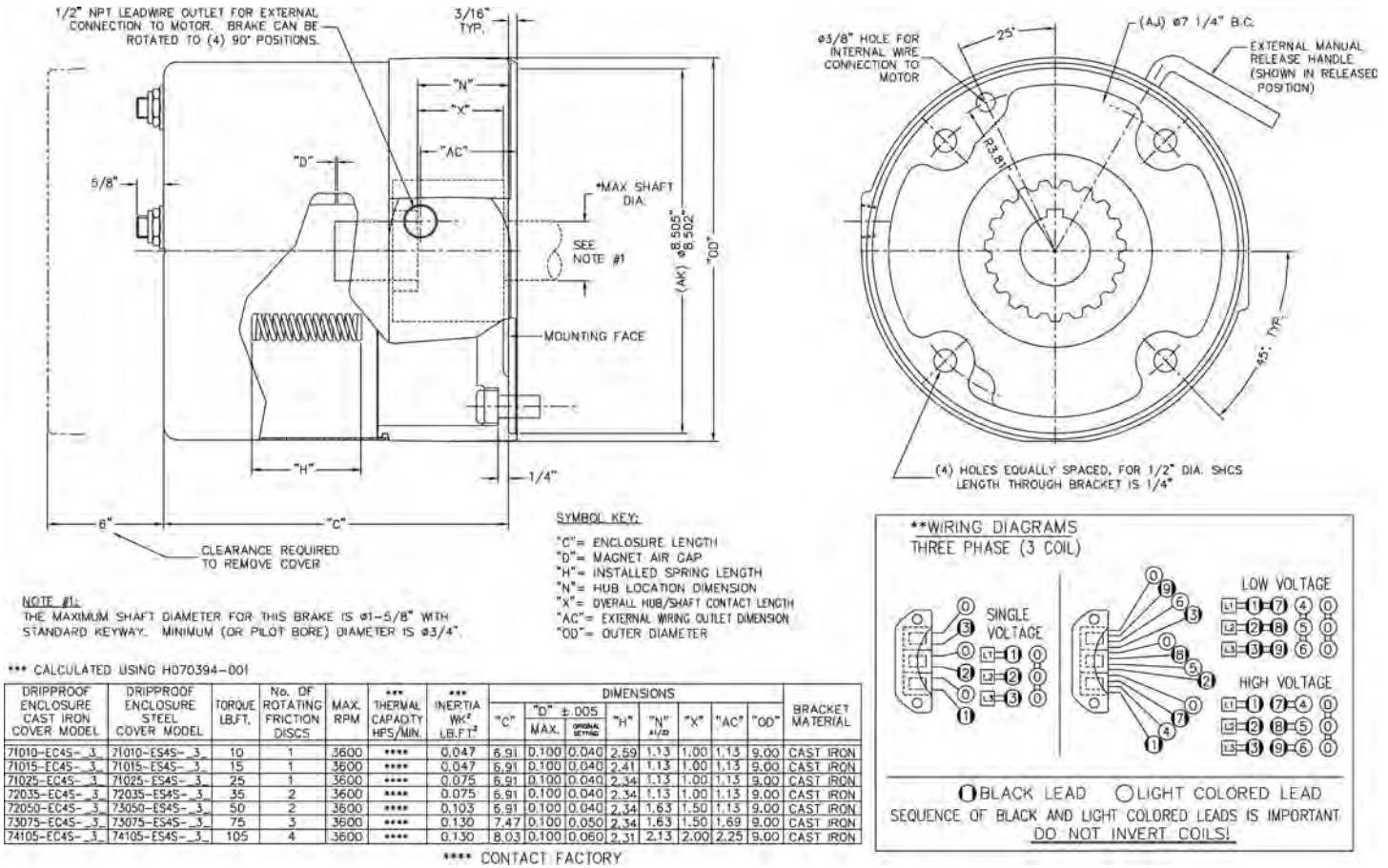

Figure 1 - Brake Outline

RECOMMENDED TOOLS AND HARDWARE

NOTE: The following tools and hardware are required for installing the brake onto a motor or mounting bracket. Use proper torque when required to ensure fasteners do not loosen during operation.

- 3/4 INCH HEX WRENCH OR RATCHET/SOCKET
- 3/16 HEX BIT SOCKET (OR KEY)
- TORQUE WRENCH
- QUANTITY (4), 1/2 diameter SHCS, MINIMUM 1" LONG (see installation note #4 below)
- 3/8 HEX BIT SOCKET (OR KEY)

INSTALLATION

(See Figures 1, & 2, Table 1)

1. Remove hub (99) from brake and position on motor shaft with key according to dimension "N" per figure 1. Stamped part number on hub should face away from motor. Tighten hub set screws with 18 lb.ft. torque.
2. Remove temporary cover nut and cover (67). Set cover aside. Discard temporary nut.
3. Place brake on motor, guiding discs on hub.
4. Bolt brake to motor "C" face with four socket head cap screws. See Figure 1 to help in determining proper bolt length. Final bolt thread pitch, length and mounting torque is dependent on the material and depth of the threaded holes in the mounting face.
5. Connect coil leads per appropriate wiring diagram in Figure 1 and replace cover (67).
6. Use provided nylon locking nuts (71) to secure cover (67).

MAINTENANCE

CAUTION: Before attempting to service or remove any components, make certain that the power is disconnected and that the load is completely removed, secured or blocked to prevent injury or property damage.

Wear Adjustment

CAUTION: Load to be removed or blocked. Brake may be inoperative during this procedure.

Before air gap "D" reaches .100", adjustment is required. Any delay in adjusting the magnet air gap will result in eventual loss of torque. Refer to Fig. 1, 2 & 3.

1. To adjust, remove cover locknuts/seals (70 & 71) and cover (67) to expose wear adjusting screws on item (32) and expose magnet air gap "D".
2. Measure air gap "D" using 3/8" to 1/2" wide feeler gauge. (Measure at center of magnet.)
3. Turn two adjusting screws on item(32) until air gap "D" measures:
 - .035/.045 for 1 disc models
 - .035/.045 for 2 disc models
 - .045/.055 for 3 disc models
 - .055/.065 for 4 disc models

Air gap should be the same on both sides.

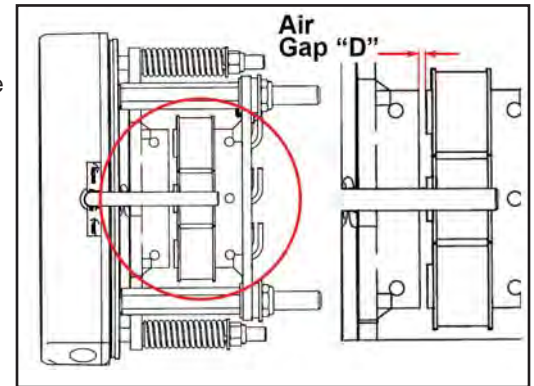

Figure 3 - Air Gap

Torque Adjustment

CAUTION: Load to be removed or blocked. Brake may be inoperative during this procedure.

The magnetic disc brake is factory set for rated static torque. The brake can be adjusted to reduce torque which increases stopping time. Do not attempt to adjust brake for higher torque, as this will cause premature coil burnout. (Refer to Fig. 1 & 2)

1. To adjust, remove cover locknuts (71) and cover (67) to expose torque locknuts (44), which are above torque springs (42).
2. To increase stopping time and reduce torque, turn two locknuts (44) counterclockwise, increasing spring length. Each full turn reduces torque 7% to 10% depending upon the model.

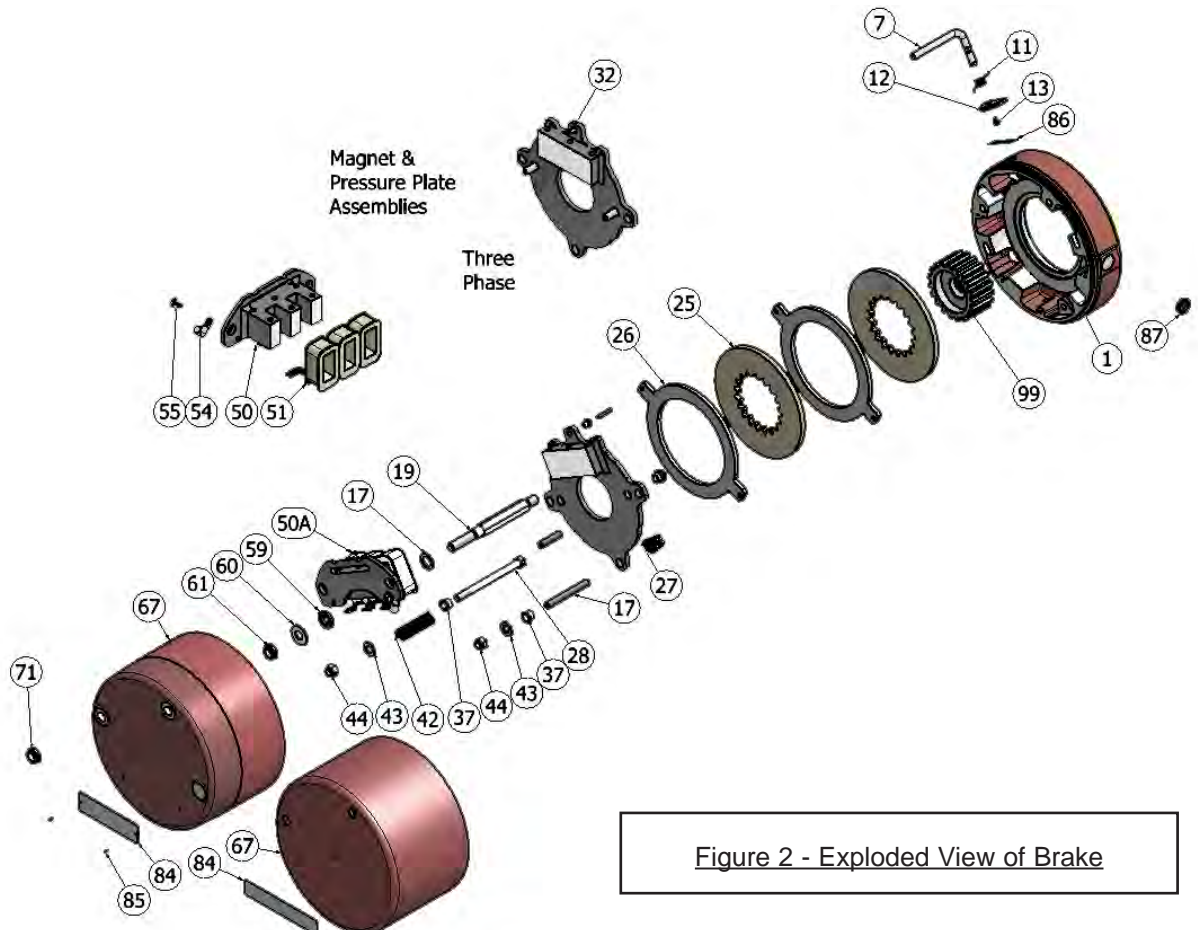

Figure 2 - Exploded View of Brake

Friction Disc Replacement

CAUTION: Load to be removed or blocked. Brake will be inoperative during this procedure.

If brake model number has a suffix VO, VU, or VA for vertical mounting, see page 8. When rotating friction disc (25) wears to one-half of the original thickness, or 0.156", replace disc:

1. **Removing electromagnet assembly**
Disconnect power.
2. Remove cover locknuts/seals (70 & 71) and cover (67).
3. Remove electromagnet assembly (32 & 50A) by removing nuts and washers (61, 60, & 59) from the magnet assembly (50A). Remove magnet assembly (50A). Remove all nuts, washers, and springs (44, 43, & 42) from pressure plate (32). Remove pressure plate (32) by rotating counter-clockwise to remove torque spring bolts (28) from slots in brake bracket (1).
4. **Replacing the friction disc**
Remove worn rotating discs (25) and stationary discs (26). Replace worn discs and install new discs in the same order.
5. **Re-assembly of electromagnet assembly (15) Refer to Fig. 1 & 2.** Reinstall pressure plate (32) by rotating clockwise to engage both torque spring bolts (28) into slots in brake bracket (1). Replace all nuts, washers, and springs (42, 43, & 44). Nut (44) on the pivot post (17) should be adjusted, so the distance from the bottom of the pressure plate (32) to the top of the brake bracket (1) is 7/16". Reinstall magnet assembly (50A) and install nuts and washers (59, 60, & 61). Nut (61) should be torqued to 20 lb-ft.
6. Readjust magnet air gap "D" as described under "Wear Adjustment".
7. Reset spring height according to brake model number in Fig.1 from the top of the spring (42) to the bottom of the pressure plate (32).
8. Energize coil. Magnet should be quiet; if not, refer to "Pivot Stud Adjustment".
9. Check manual release operation before completing installation. Adjust per "Manual Release Adjustment" if required.
10. **Completing installation**
Replace cover (67) and cover locknuts/seals (70 & 71). Tighten nut (71) with 30lb-in. Reconnect power.

Magnet Assembly Replacement

CAUTION: Load to be removed or blocked. Brake will be inoperative during this procedure.

1. Disconnect power supply.
2. Remove cover locknuts/seals (70 & 71) and cover (67).
3. Remove nuts and washers (59, 60, & 61) from magnet assembly (50A) & remove assembly.
4. Replace with new magnet assembly (50A) and install nuts and washers (59, 60, & 61). Nut (61) should be torqued to 20 lb-ft.
5. Place coil lead wires around mounting bracket (1) to the same side as the wire outlet position or internal wire outlet. Connect coil lead wires per Fig. 1.
6. Set air gap "D" as described under "Wear Adjustment".
7. Energize coil. Magnet should be quiet; if not, refer to "Pivot Stud Adjustment".
8. Check manual release. If it does not operate properly, adjust as outlined under "Manual Release Adjustment".
9. Replace cover (67) and cover locknuts/seals (70 & 71). Tighten nut (71) to 30 lb-in. Reconnect power.

Pressure Plate Replacement

CAUTION: Load to be removed or blocked. Brake will be inoperative during this procedure.

If you replace the magnet assembly, it may be necessary to replace the pressure plate (32). If it is badly deformed, it will be difficult to make the magnet quiet.

1. To replace, remove electromagnet assembly (32 & 50A) from brake. See "Friction Disc Replacement Steps 1-3".
2. Replace with new pressure plate (32) and reassemble per "Friction Disc Replacement Steps 5-10".

Pivot Stud Adjustment

CAUTION: Load to be removed or blocked. Brake will be inoperative during this procedure.

This adjustment is made at the factory and may be required when replacing the magnet assembly (50A) or the pressure plate (32). The purpose is to regulate the height of the pressure plate (32) so that when the magnet (50A) is energized, the pressure plate (32) is parallel with it. This is required so that the magnet will be quiet.

NOTE: Cover (67) must be removed to make this adjustment.

1. To adjust: Rotate nut (44) with washer (43) on pivot post (17) until the height from the bottom of the pressure plate (32) to the top of the brake bracket (1) is near 7/16".
2. Energize the magnet and turn nut (44) counterclockwise slowly until the magnet becomes noisy. Turn nut (44) clockwise until the magnet becomes quiet. Hold nut in this position and turn magnet on and off to make sure the magnet does not become noisy.
3. Operate the manual release. If the release does not operate properly, see "Manual Release Adjustment".

Manual Release Adjustment

CAUTION: Load to be removed or blocked. Brake will be inoperative during this procedure.

The manual release (7) may require adjustment after replacing the electromagnet assembly (50A & 32), magnet (50A), or pressure plate (32). It also may be required if adjustments are made on the pivot post nut (44).

The release is working properly if:

- You turn release (7) clockwise to stop and the brake is released;
- The release returns to its normal position automatically when power is applied to the magnet.

NOTE: Cover (67) must be removed to make this adjustment.

- To adjust: Set air gap "D" as described under "Wear Adjustment".
- If the brake does not release, turn the adjusting screw above the manual release cam (12) on the pressure plate (32) counterclockwise and try again.
- If the manual release (7) does not return to its normal position automatically, turn the adjusting screw above the manual release cam (12) on the pressure plate (32) clockwise and try again.

NOTE: You may have to repeat Steps 2 or 3 to get the release to operate properly. It is important that the manual release returns to its normal position automatically when power is applied to the magnet.

Manual Release Assembly

Refer to Fig. 2

- Place the end of the manual release shaft (7) with the threaded hole through the hole in the bracket (1).
- Slide the return spring (11) over the shaft. The straight leg of spring should bottom out on the bracket and the bent piece should point towards the brake hub (99) or motor shaft.
- The manual release cam (12) should be placed on the Double-D end of the shaft with the bent part of the return spring (11) resting just above the Double-D portion of the manual release cam (12).
- Install manual release screw (13) to hold manual release cam (12) to the manual release (7).
- Adjust release. See "Manual Release Adjustment".

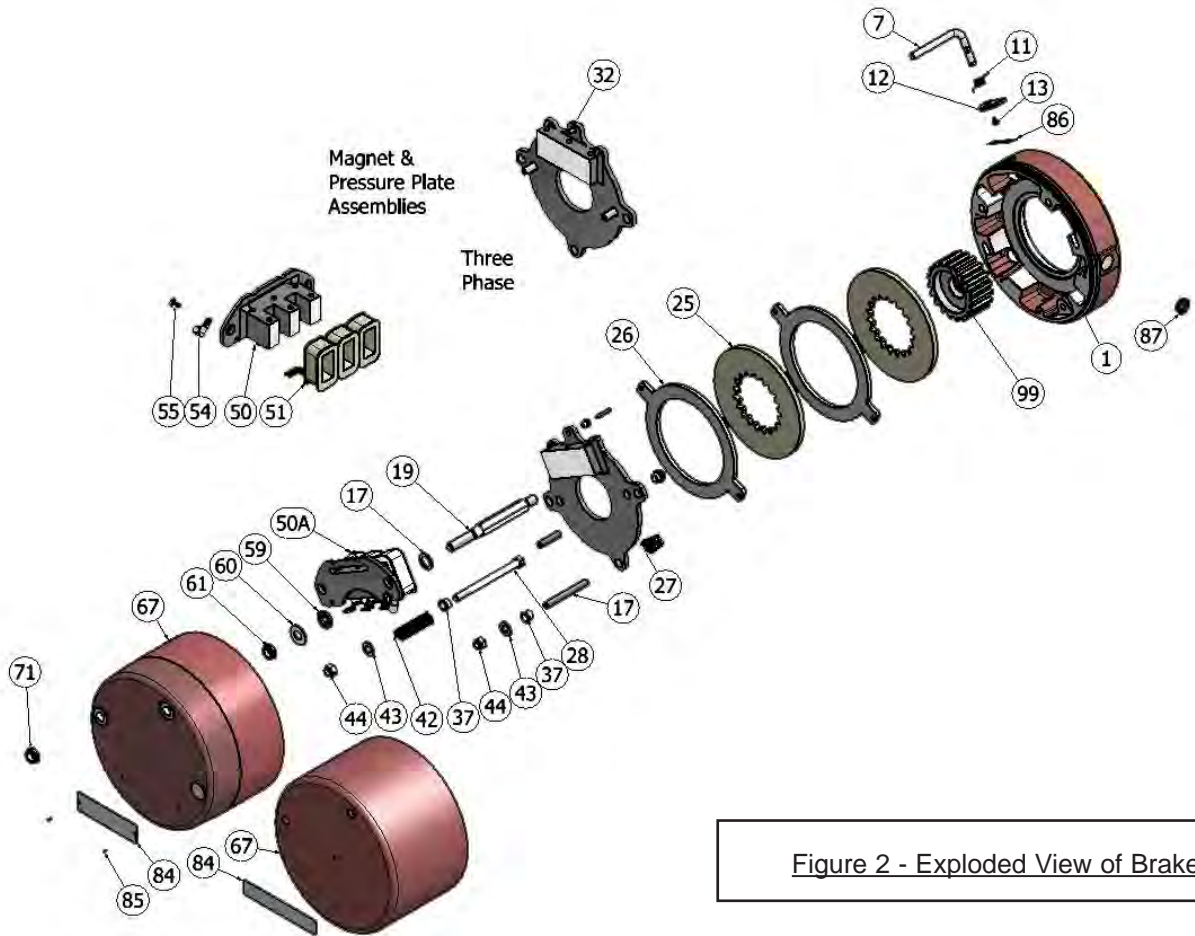

Figure 2 - Exploded View of Brake

REPLACEMENT PARTS LIST

(See Figure 2)

ITEM NO.	DESCRIPTION	MODEL												PART NO.				
		Cast Iron Cover Endmount						Steel Cover Endmount										
		71010-EC4S	71015-EC4S	71025-EC4S	72035-EC4S	72050-EC4S	73075-EC4S	74105-EC4S	71010-ES4S	71015-ES4S	71025-ES4S	72035-ES4S	72050-ES4S		73075-ES4S	74105-ES4S		
1	Bracket assembly, 1&2 disc	1	1	1	1				1	1	1	1						K070579-XXX
1	Bracket assembly, 3 disc					1							1					K070580-XXX
1	Bracket assembly, 4 disc						1	1							1	1		K070581-XXX
7	Handle, manual release	1	1	1	1	1	1	1	1	1	1	1	1	1	1	1	1	H070422-001
11	Spring, return manual release	1	1	1	1	1	1	1	1	1	1	1	1	1	1	1	1	G070846-001
12	Cam, manual release	1	1	1	1	1	1	1	1	1	1	1	1	1	1	1	1	H070393-001
13	Screw, retaining, cam	1	1	1	1	1	1	1	1	1	1	1	1	1	1	1	1	W001045-043
17	Post, pivot	1	1	1	1	1	1	1	1	1	1	1	1	1	1	1	1	W002005-168
19	Stud post, magnet assembly/cover	2	2	2	2	2	2	2	2	2	2	2	2	2	2	2	2	H070395-001
25	Disc, rotating friction	1	1	2	2	3	4	4	1	1	2	2	3	4	4	4	4	H070394-001
26	Disc, stationary	1	1	2	2	3	4	4	1	1	2	2	3	4	4	4	4	K070560-001
27	Spring, pivot	1	1	1	1	1	1	1	1	1	1	1	1	1	1	1	1	G070847-001
28	Bolt, torque spring	2	2	2	2	2	2	2	2	2	2	2	2	2	2	2	2	W001007-069
32	Pressure plate assembly, three phase	1	1	1	1	1	1	1	1	1	1	1	1	1	1	1	1	H070423-001
37	Bushing, flanged	3	3	3	3	3	3	3	3	3	3	3	3	3	3	3	3	W013007-061
42	Spring, torque, silver							2									2	G070848-001
42	Spring, torque, gold	2	2	2	2	2	2		2	2	2	2	2	2	2			G070849-001
43	Washer, flat	3	3	3	3	3	3	3	3	3	3	3	3	3	3	3	3	W004002-008
44	Nut, adjustment	3	3	3	3	3	3	3	3	3	3	3	3	3	3	3	3	W003013-005
46	Washer, magnet assembly base	2	2	2	2	2	2	2	2	2	2	2	2	2	2	2	2	W004004-018
50A	Magnet Assembly, three phase	1	1	1	1	1	1	1	1	1	1	1	1	1	1	1	1	H070402-XXX
50	Magnet frame, three phase	1	1	1	1	1	1	1	1	1	1	1	1	1	1	1	1	K070567-001
51	Coil, Magnet, three phase	3	3	3	3	3	3	3	3	3	3	3	3	3	3	3	3	H020003-XXX
54	Clamp, cable	1	1	1	1	1	1	1	1	1	1	1	1	1	1	1	1	W021008-005
55	Screw, cable clamp	1	1	1	1	1	1	1	1	1	1	1	1	1	1	1	1	W001038-143
59	Washer, shock absorber	2	2	2	2	2	2	2	2	2	2	2	2	2	2	2	2	G070850-001
60	Washer, capture	2	2	2	2	2	2	2	2	2	2	2	2	2	2	2	2	W004004-017
61	Nut, nylock magnet assembly	2	2	2	2	2	2	2	2	2	2	2	2	2	2	2	2	W003001-20
67	Cover, cast iron	1	1	1	1	1	1	1										K070554-001
67	Cover, steel								1	1	1	1	1	1	1	1	1	K070545-002
71	Nut, cover	2	2	2	2	2	2	2	2	2	2	2	2	2	2	2	2	W003001-020
84	Nameplate, mylar								1	1	1	1	1	1	1	1	1	K060407-001
84	Nameplate, metal	1	1	1	1	1	1	1										K070574-001
85	Drive screw	2	2	2	2	2	2	2										W001012-048
86	Release label	1	1	1	1	1	1	1	1	1	1	1	1	1	1	1	1	G070852-001
87	Capplug, 1/2 NPT	1	1	1	1	1	1	1	1	1	1	1	1	1	1	1	1	W008003-001
99	Hub assembly 1 disc	1	1	1					1	1	1							H070409-XXX
99	Hub assembly 2 disc - 35 lb-ft				1							1						H070412-XXX
99	Hub assembly 2 disc - 50 lb-ft					1							1					H070414-XXX
99	Hub assembly 3 disc						1							1				H070417-XXX
99	Hub assembly 4 disc							1								1		H070420-XXX

XXX - Part number depends upon brake model number

Table 1 - Parts List

EXPLODED VIEW

(See Table 1)

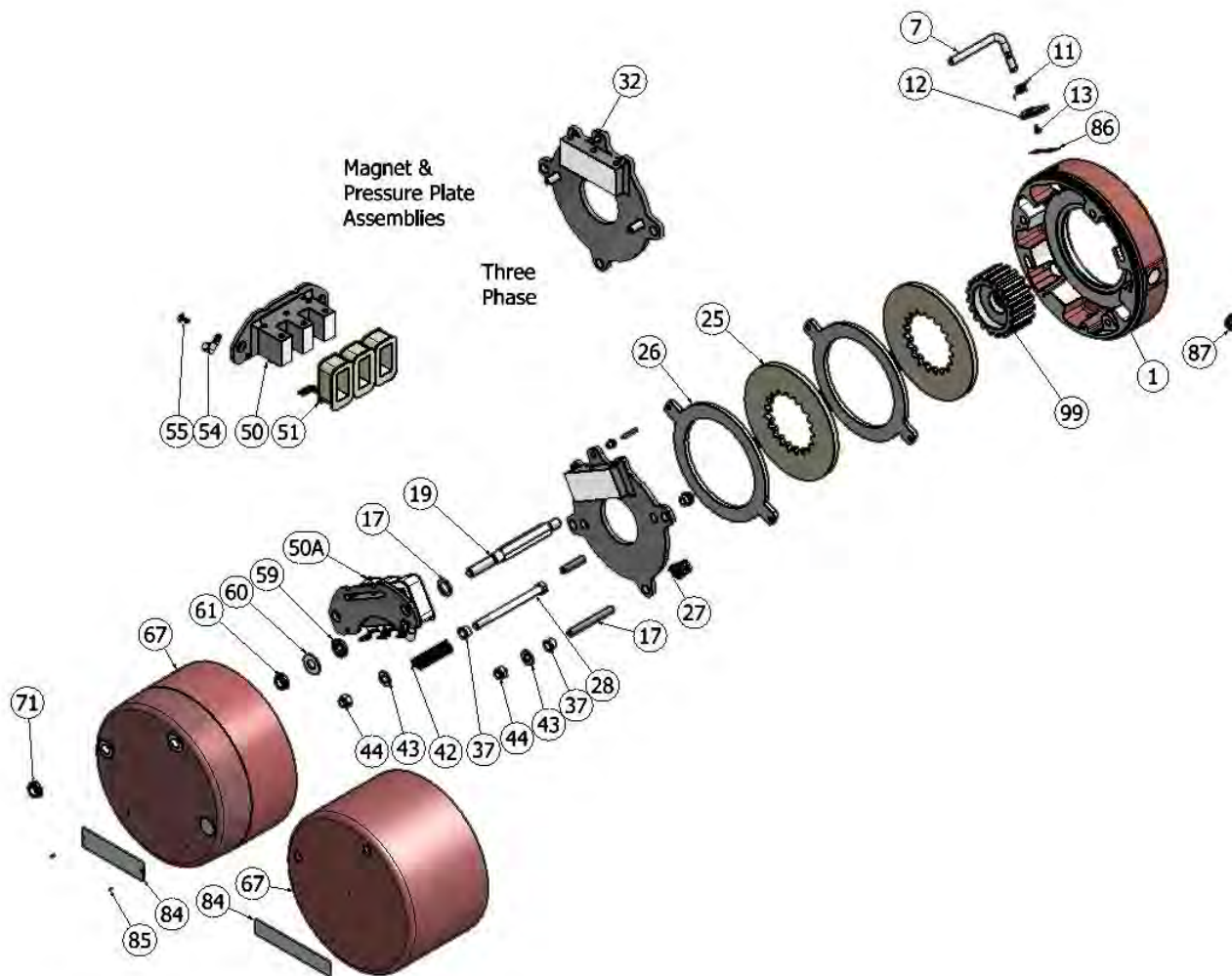

Figure 2 - Exploded View of Brake

VERTICAL MOUNTING

Installation and Adjustment

Installation and adjustment of the vertically mounted brake is the same as on the standard model.

Friction Disc Replacement

When replacing friction discs, follow procedure outlined on page 3 with this addition:

Care must be taken to insure proper insertion of disc separating springs. Springs are color coded for easy identification, and reference is made to spring color (See table to the right & diagram below). Since the installation order of the disc springs is dependent on brake mounting position (above or below motor), it is important to consult the correct diagram for spring location.

													BILL OF MATERIAL		
FIG 12	FIG 11	FIG 10	FIG 9	FIG 8	FIG 7	FIG 6	FIG 5	FIG 4	FIG 3	FIG 2	FIG 1		DESCRIPTION	PART NO.	ITEM
*	-	1	1	-	-	1	1	-	-	1	1		BRACKET (2 DISC)	L070XXX-XXX	1
*	-	1	-	-	1	-	-	-	1	-	-		BRACKET (3 DISC)	L070XXX-XXX	1
*	1	-	-	1	-	-	-	-	1	-	-		BRACKET (4 DISC)	L070XXX-XXX	1
*	4	3	2	1	4	3	2	1	4	3	2	1	ROTATING DISC	H070394-001	2
*	4	3	2	1	4	3	2	1	4	3	2	1	STATIONARY DISC	K070560-001	3
	-	-	2	2	-	-	2	-	-	2	2		VERTICAL PIN (1&2 DISC)	W005003-147	4
	-	2	-	-	2	-	-	-	2	-	-		VERTICAL PIN (3 DISC)	W005003-149	4
	2	-	-	2	-	-	-	2	-	-	-		VERTICAL PIN (4 DISC)	W005003-151	4
	-	-	-	2	-	-	-	2	2	2	2		SPRING (RED)	G070836-001	5
	-	-	-	-	-	-	-	2	2	2	-		SPRING (BLUE)	G070837-001	5
	-	-	-	-	-	-	-	2	2	-	-		SPRING (YELLOW)	G070838-001	7
	-	-	-	-	-	-	-	2	-	-	-		SPRING (GREEN)	G070839-001	8
	-	-	-	2	2	2	-	-	-	-	-		SPRING (ORANGE)	G070840-001	9
	-	-	-	2	2	-	-	-	-	-	-		SPRING (WHITE)	G070841-001	10
	-	-	-	2	-	-	-	-	-	-	-		SPRING (BLACK)	G070842-001	11
	-	-	4	-	-	-	-	-	-	-	-		SPRING (SILVER)	G070843-001	12
	-	6	-	-	-	-	-	-	-	-	-		SPRING (PURPLE)	G070844-001	13
	8	-	-	-	-	-	-	-	-	-	-		SPRING (PINK)	G070845-001	14
	-	-	-	-	-	-	-	1	1	1	1		NAMEPLATE (ABOVE MOTOR (VO))	H060267-004	15
	-	-	-	1	1	1	1	-	-	-	-		NAMEPLATE (BELOW MOTOR (VU))	H060267-005	16
	1	1	1	1	-	-	-	-	-	-	-		NAMEPLATE (ALL POSITION (VA))	H060267-006	17

*FOR REFERENCE ONLY

