



70 Series Hazardous Brake Instructions

READ THIS BULLETIN CAREFULLY BEFORE INSTALLING OR OPERATING THE 70 SERIES BRAKE. FAILURE TO COMPLY WITH THESE INSTRUCTIONS CANCELS ALL WARRANTIES SINCE THE SAFETY OF THE UNIT MAY BE ENDANGERED BY IMPROPER INSTALLATION OR OPERATING PROCEDURES.

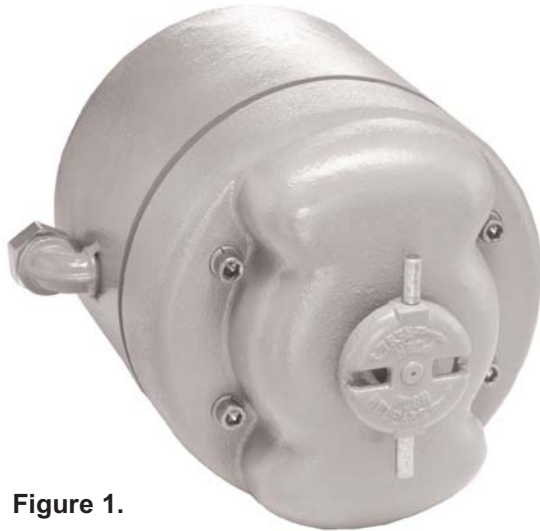

Figure 1.

| MOTOR MOUNTED* | | FOOT MOUNTED | |
|----------------|------------|--------------|------------|
| MODEL NO. | Torque | MODEL NO. | Torque |
| R71010-9 | 10 lb. ft. | FR71010-9 | 10 lb. ft. |
| R71015-9 | 15 lb. ft. | FR71015-9 | 15 lb. ft. |
| R72025-9 | 25 lb. ft. | FR72025-9 | 25 lb. ft. |
| R73035-9 | 35 lb. ft. | FR73035-9 | 35 lb. ft. |
| R74050-9 | 50 lb. ft. | FR74050-9 | 50 lb. ft. |
| R75075-9 | 75 lb. ft. | FR75075-9 | 75 lb. ft. |

Table 1. List of Models

*If a hazardous location brake is purchased by other than an authorized electric motor manufacturer, a Foot Mounted brake must be purchased to obtain the UL label.

DESCRIPTION

The 70 Series Brake is a direct acting, electro magnetically released, spring set unit that utilizes rotating and stationary disc contact to supply positive braking action with quick release and setting capabilities at all times. Brakes which are not provided with a floor mounting bracket are intended to be mounted as an integral part of electric motors listed for corresponding hazardous locations where the acceptability of the combinations has been determined by Underwriter's Laboratories, Inc. The explosion-proof assembly is completed by assembly of the brakes to the motors.

CAUTION

DO NOT OPERATE MANUAL RELEASE OR ENERGIZE BRAKE COIL BEFORE INSTALLATION IN ORDER TO PRESERVE PRE-ALIGNMENT OF ROTATING DISCS FOR EASE OF INSTALLATION.

USE ONLY HUB FURNISHED BY DINGS SPECIFICALLY FOR USE IN HAZARDOUS LOCATION BRAKES. DO NOT OPERATE BRAKES IN EXPLOSIVE ATMOSPHERE WITH COVER OR COVER BOLTS REMOVED.

MANUAL RELEASE (See Figure 1)

To manually release brake, push in release knob and rotate counterclockwise until strikes stop-pin. Brake will remain released until release knob is pushed in and turned clockwise or until power is restored, automatically resetting the brake.

THERMAL RELEASE

If the brake overheats, the thermal release mechanism will release spring pressure on the friction discs, releasing brake. To reset thermal release, allow brake to cool, then push in release knob (17) and rotate clockwise until it strikes the stop-pin. Check brake operation as overheating may indicate a broken lead wire or burned out coil.

The thermal release mechanism has been calibrated at the factory and the setting of the bimetal element and control rod **MUST NOT BE DISTURBED**. If the mechanism does not function properly, the complete pressure plate assembly (9), complete magnet plate assembly (3), release gears (34) and items 31 through 50 must be returned to the factory for adjustments.

G060629-006

WARNINGS

- A. Read this bulletin carefully before installing or operating the brakes. Failure to comply with the installation or operating instructions cancels all warranties and may cause injury to personnel and damage to property.

- B. **DESCRIPTION**

The 70 Series brake for hazardous location is a direct acting, electromagnetically released, spring set brake that utilizes rotating and stationary disc contact to supply positive braking action. Brakes can be mounted independently of any other equipment by using a U.L. listed foot mounting bracket, or mounted to an electric motor listed for hazardous locations. The brakes are equipped with a thermal overload mechanism that prevents the external surfaces of the unit from exceeding the temperature rating for the brake.

- C. **OPERATING INFORMATION**

When the external surface of the brake approaches its temperature rating, the thermal overload mechanism will automatically release the brake and hold it in the released position. This prevents ignition of gases or suspended solids, assuming that brake's temperature rating is less than the air ignition temperature. The thermal overload mechanism prevents the surface temperature of the brake from rising to a level that could ignite the surrounding gases or dusts by releasing the brake and therefore, stopping a further increase in temperature. Once the brake has been released by the thermal overload mechanism, control over the rotation of the motor and the load is lost. This uncontrolled rotation of the motor and movement of the load could cause injury to personnel and damage to property.

The thermal overload mechanism can be reset manually after a cooling off period. Before resetting, the root cause for actuating the thermal overload mechanism needs to be determined and corrected.

To minimize the possibility of overheating the brake to a point where the thermal overload mechanism will be actuated, the performance of the brake has to be matched to the requirements of the application.

When selecting the brake model, consideration has to be given to brake torque, thermal capacity, electrical power supply, housing material and any unusual conditions.

BRAKE TORQUE

As a general rule, brake torque is matched to the full load motor torque (brake and motor shaft at the same speed). Depending on the type of application, the torque sometimes is increased by a safety factor of 1.5 to 2. If factors such as stopping time, travel distance during stopping and others, are important, the exact torque requirement has to be calculated, using the methods contained in Dings selection guide.

THERMAL CAPACITY

Thermal capacity describes the capacity of the brake to perform the maximum number of stops without excessive heat buildup that will actuate the thermal overload mechanism or damage internal brake parts. The maximum number of stops depends on the rating of the brake, load to be stopped and speed from which stops are made. To calculate the thermal capacity requirements of the application, use the methods contained in Dings selection guide.

ELECTRICAL POWER SUPPLY

The coil of the electromagnet, which supplies the releasing force under normal operating conditions, will operate properly with a tolerance of plus or minus 10% of rated voltage. A voltage higher than 110% will shorten the life of the coil considerably due to the higher temperature generated inside the coil. A voltage of less than 90% may prevent the armature from moving towards the magnet frame. If this occurs, the coil will burn out within months.

UNUSUAL CONDITIONS

Please consult Dings Home Office, if ambient temperature is above 40°C (104°F), brake shaft speed is over 3600 RPM, or any other unusual conditions exist.

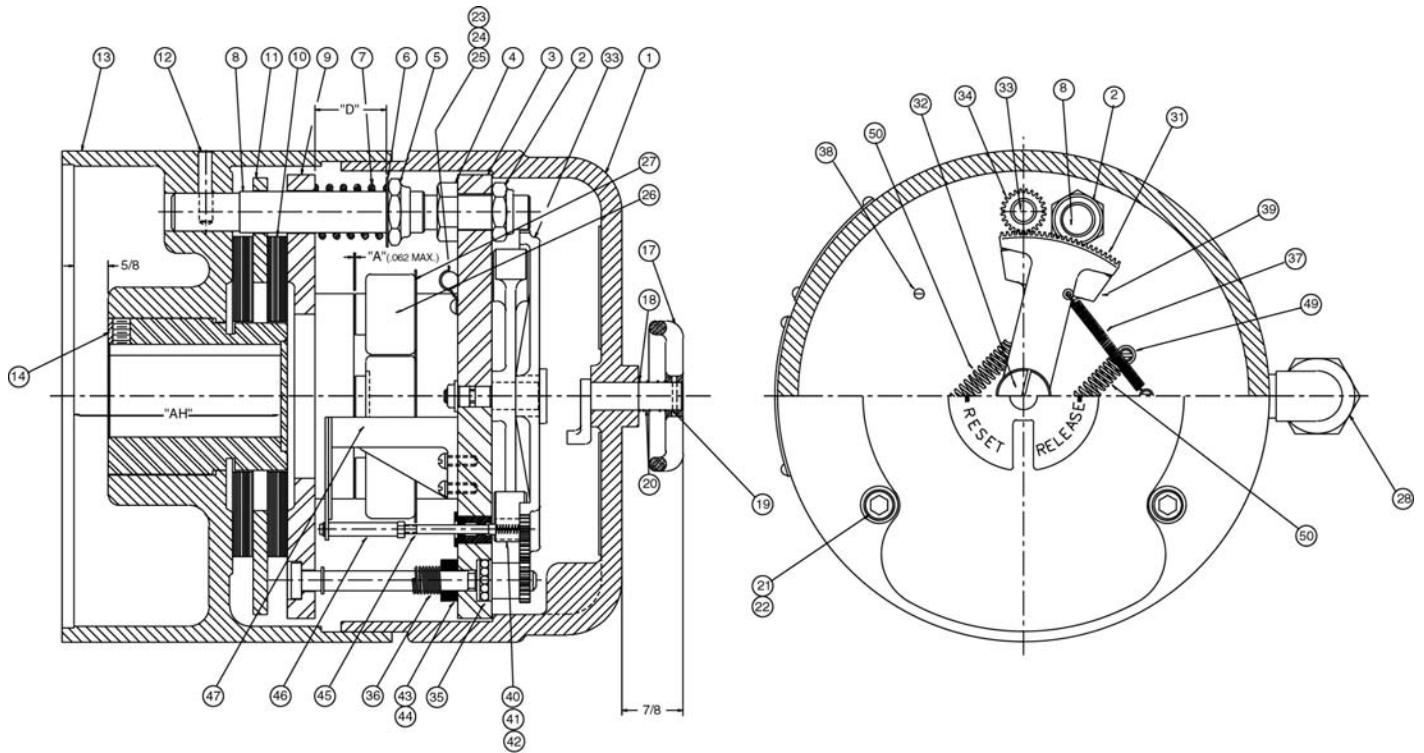

| Item No. | Description | Part No. | Item No. | Description | Part No. |
|----------|--|-------------|----------|------------------------------------|-------------|
| 1 | Cover | K070091-001 | 25 | Clamp Screw | W001002-051 |
| 2 | Gap Adjusting Nut | W003001-022 | 26 | Coil, 3 Phase (included in item 3) | H070033-*** |
| 3 | Magnet & Coil Assembly, 3 Phase | K070283-*** | 26 | Coil, 1 Phase (included in item 3) | H070035-*** |
| 4 | Gap Adjusting Nut | W003008-022 | 27 | Insulating Washer, 3 Phase | G070037-001 |
| 5 | Torque Adjusting Nut | W003001-023 | 27 | Insulating Washer, 1 Phase | G070029-001 |
| 6 | Adjusting Nut Washer | W004004-014 | 28 | Condulet Assembly | G070148-001 |
| 7 | Torque Spring, 10 & 35 lb. ft. | G070011-001 | 29 | Nameplate | H050020-001 |
| 7 | Torque Spring, 15 & 75 lb. ft. | G070012-001 | 30 | Press Nut | W003012-024 |
| 7 | Torque Spring, 25 & 50 lb. ft. | G070019-001 | 31 | Drive Gear | G070167-001 |
| 8 | Stud | G070175-*** | 32 | Pivot Stud | G070153-001 |
| 9 | Pressure Plate | K070048-002 | 33 | Release Rod w/ Snap Ring | G070134-002 |
| 10 | Rotating Friction Disc 10 - 50 lb. ft. | H070103-005 | 34 | Release Gear | G070140-001 |
| 10 | Rotating Friction Disc 75 lb. ft. | H020009-002 | 35 | Release Bearing | W009002-001 |
| 11 | Stationary Disc 25 - 75 lb. ft. only | K070485-001 | 36 | Release Rod Spring | G060010-001 |
| 12 | Stud Lock Pin | W005005-001 | 37 | Release Reset Spring | G070159-001 |
| 13 | Brake Bracket | L070066-*** | 38 | Release Stop Stud | G070144-001 |
| 14 | Hub Assembly | H070044-*** | 39 | Driver | G070152-001 |
| 15 | Mounting Bolt (not shown) | W001013-132 | 40 | Lock Bushing | G070119-001 |
| 16 | Locking Screw | W002002-001 | 41 | Lock Pin | G070157-001 |
| 17 | Manual Release & Reset Knob | G070141-003 | 42 | Lock Spring | G070158-001 |
| 18 | Knob Release Spring | G070202-001 | 43 | Felt Washer | G070162-001 |
| 19 | Knob Roll Pin | W005003-044 | 44 | Washer | W004001-003 |
| 20 | Reset Arm | G070156-001 | 45 | Control Rod Wiper Assembly* | |
| 21 | Cover Bolts | W001013-108 | 46 | Control Rod Assembly* | |
| 22 | Lock Washer | W004006-008 | 47 | Thermal Release Bracket Assembly* | |
| 23 | Wiring Harness Guide | G070218-001 | 49 | Driver Spring Stud | G070143-001 |
| 24 | Wiring Harness Clamp | W021001-001 | 50 | Drive Spring (1, 2, & 3 Disc) | G070160-001 |
| | | | 50 | Drive Spring (4 & 5 Disc) | G070160-002 |

*Install only at factory.

***Varies by brake model—provide model and serial number.

INSTALLATION OF BRAKE ON MOTOR ENDSHIELD (See Figures 2, 3 and Table 4)

Do not operate manual release or energize brake coil before installation in order to preserve pre-alignment of rotating disc for easy installation of brake to motor.

Because of the close fit on all joints (bracket, cover, hub), care should be taken to prevent damage to all machined surfaces.

Do not operate brake in hazardous location with cover removed. All testing must be done in a non-explosive atmosphere.

1. Remove hub (14) from brake and mount hub with key (not supplied by Dings) on motor shaft per dimension "BC" shown in Figure 2. Be sure that hub used is item supplied by Dings for hazardous location applications. Tighten both set screws to 8-10 lb. ft. torque.
2. Remove four cover bolts (21) and tap cover with soft mallet. Remove cover (1). Do not operate the manual release (17) until brake is installed.
3. Inspect motor "C" flange and remove any nicks or burrs. This will assure a precision fit of brake to motor flange. Slide brake over hub (14), engaging teeth of rotating disc (10) and hub.
4. Install four mounting bolts (15) and tighten. Install four locking set screws (16) and tighten to 40 lb. ft. torque. This seals flame path around mounting bolts. Check rotation of hub to make certain it does not rub in bracket (13). Diametrical clearance or hub outside diameter to bracket bore shall not exceed .024".
5. Connect brake leads to power as shown in Figure 3. All wiring should be positioned to prevent pinching or chafing and all connections well taped to prevent grounding.
6. Replace cover (1). This may be done more easily by threading a 3/8" dia. by 5" long stud (threaded one end 3/8-16NC) into one cover bolt hole in magnet plate assembly (3) as guide. Slide cover into position using stud as a guide and tap with soft mallet until cover seats. Use care in assembly. Insert 3 cover bolts (21) and finger tighten. Remove guide stud and insert fourth cover bolt. Draw up all bolts evenly and tighten until spring washer (22) is fully compressed. A loose or missing bolt will render the brake unsafe for operation in hazardous locations.

INSTALLATION OF BRAKE WITH ADAPTER ON MOTOR ENDSHIELD (See Figure 4)

7. Inspect motor "C" flange and remove any nicks or burrs. This will insure a precision fit of adapter to the motor flange. Mount adapter to motor flange using the four bolts and lock washers supplied. A soft mallet may be used to tap adapter into place. All bolts should be drawn up evenly and tight.
8. Check alignment of adapter. Clamp dial indicator to brake hub (position A) and measure pilot eccentricity. This must not exceed .006" total indicator reading for a full revolution of hub. Reposition dial indicator (position B) and check adapter face runout which must not exceed .006" total indicator reading a full revolution of the shaft. Remove hub (14) from brake and mount hub with key (not supplied by Dings) on motor shaft per dimension shown in Figure 2. Tighten both setscrews to 8-10 lb. ft. torque. Complete mounting of brake per paragraphs 2 through 6.

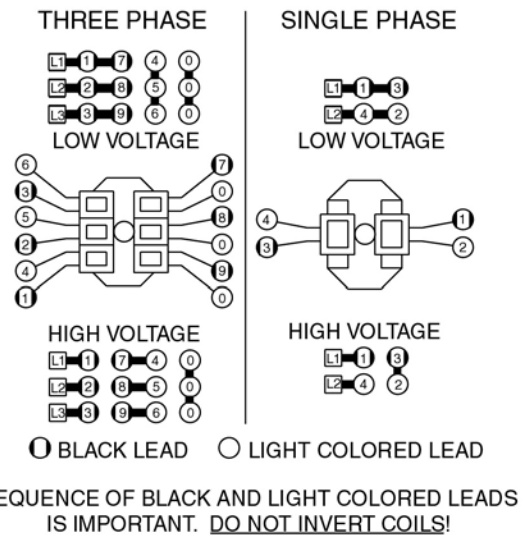

Figure 2. Wiring Connections

| ITEM NO. | DESCRIPTION | PART NO. | NO. REQ. |
|----------|-----------------------------|----------|----------|
| 3 | Magnet assembly with coils | -- | 1 |
| 26 | Magnet coil (3 phase) | H070033 | 6 |
| 26A | " (1 phase) | H070035 | 2 |
| 27 | Insulating washer (3 phase) | G070037 | 4 |
| 27A | " (1 phase) | G070029 | 4 |
| 51 | Shading coil (1 phase only) | G070032 | 2 |

Table 2. Electrical Parts List

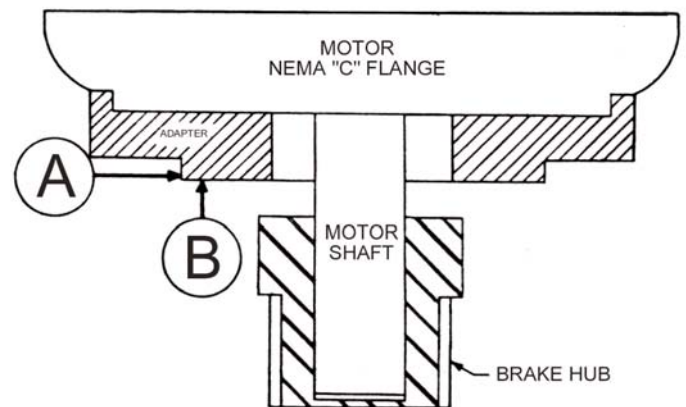

Figure 3. Adapter Installation

| Model Number | Torque Lb. Ft. | "BC" +1/32 -.000 | Spring Length "D" | Shaft Length "AH" Max. | Magnet Gap "A" | |
|--------------|-------------------|---------------------|----------------------|---------------------------|----------------|--------|
| | | | | | A-Min. | A-Max. |
| R71010-9 | 10 | 5/8 | 1-5/16 | 3-7/16 | .030 | .062 |
| R71015-9 | 15 | 5/8 | 1-5/16 | 3-7/16 | .030 | .062 |
| R72025-9 | 25 | 5/8 | 1-5/16 | 3-3/4 | .030 | .062 |
| R73035-9 | 35 | 5/8 | 1-5/16 | 4-3/8 | .035 | .062 |
| R74050-9 | 50 | 5/8 | 1-5/16 | 5-1/8 | .035 | .062 |
| R75075-9 | 75 | 5/8 | 1-5/16 | 5-1/8 | .045 | .062 |

Table 4. Adjustments

**INSTALLATION OF FOOT MOUNTING
BRAKE (See Tables 4, 5 & Figure 5)**

9. Install bracket (F1) over motor shaft extension and half-tighten capscrews (F8). The distance from the mounting face of the bracket (F1) to end of motor shaft must not exceed dimension "AH" max. (Table 5).
10. Clamp dial indicator "A" to motor shaft and position bracket (F1) with shims as necessary, by tapping with a soft mallet until dial indicator does not read over .002" total change in one full revolution of the shaft. Move dial indicator to "B" and position bracket until dial indicator does not read over .004" total change in one full revolution of shaft.
11. Draw all bolts up tight. Recheck alignment with dial indicator. Readjust if necessary until tolerances are within limits with all bolts tight. Drill eight 1/4" dia. holes into mating parts and drive dowel pins (F7) into place.
12. Mount stop bushing (F3) on shaft with clearance of .005" to .015" between bushing and bracket (F1). Mount hub (14) on shaft butting firmly against stop bushing. Complete mounting of brake per paragraphs 2 through 6.

| ITEM | DESCRIPTION | QTY | PART NUMBER |
|------|-------------------|-----|-------------|
| F1 | Foot Mtg. Bracket | 1 | K070066-001 |
| F2 | Foot Pad | 2 | G070180-001 |
| F3 | Stop Bushing | 1 | G070181-* |
| F4 | Set Screw | 2 | W002001-013 |
| F5 | Hx. Hd. Cap Screw | 4 | W001007-055 |
| F6 | Split Lockwasher | 8 | W004006-008 |
| F7 | Roll Pin | 8 | W005003-170 |
| F8 | Hx. Hd. Cap Screw | 4 | W001007-058 |
| 14 | Hub | 1 | H070044-* |
| 15 | Mounting Bolt | 4 | W001013-132 |
| 16 | Locking Screw | 4 | W002002-001 |

*Specify bore

| MODEL | 71010 | 71015 | 72025 | 73035 | 74050 | 75075 |
|-------|-------|-------|--------|---------|--------|--------|
| "AH" | 4-3/4 | 4-3/4 | 5-1/16 | 5-11/16 | 6-7/16 | 6-7/16 |

Table 5. Foot Mounting Parts

WEAR ADJUSTMENT (See Figure 2 & Table 4)

13. The magnet gap "A" increases as the friction discs wear. When magnet gap measures "A-Max," adjust to "A-Min" using gap adjusting nuts (2) and (4). Magnet gap must never exceed "A-Max" and must be adjusted periodically.

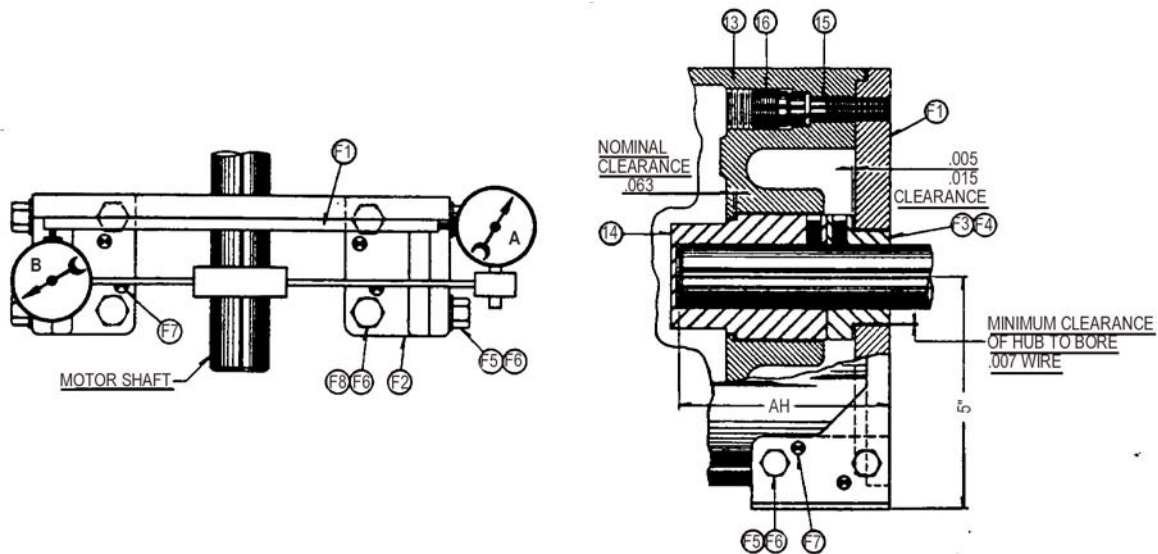

Figure 5.

TORQUE ADJUSTMENT

(See Figure 2 & Table 4)

14. Adjust length of torque springs (7) to dimension "D" for rated torque. To decrease torque, increase spring length ("D" max = 1-1/2"). Both torque springs must be adjusted to the same length.

FRICITION DISC REPLACEMENT

(See Figure 2)

15. Remove cover screws (21) and cover (1).
16. Remove pivot stud (32), reset spring (37), drive gear (31), drive spring (50), and driver (39). Unscrew release gear (34) and remove release bearing (35). Remove gap adjusting nut (2), reset spring (37) and drive spring (50).
17. Remove magnet plate (3). Take care not to bend control rod assembly (45).
18. Remove gap adjusting nut (4), torque nut (5), washer (6) and torque spring (7). Remove pressure plate (9). The friction discs (10) may now be replaced.
19. Reassemble brake. Replace pressure plate (9), torque spring (7), washer (6) and torque nut (5). Set spring length to dimension "D" (Fig. 2). Assembly gap adjusting nut (4) and magnet plate (3) taking care not to bend control rod assembly (46). Set magnet gap to dimension "A" (Fig. 2 and Table 4).
20. Install two release bearings (35) into recesses of magnet plate (3). Thread two release gears (34) onto release rods (33). Turn release gears (34) clockwise until snug but do not raise pressure plate (9). Make certain that release rods (33) are seated in the pressure plate recesses.
21. Insert lock spring (42) and lock pin (41) in the underside of the driver (39) and center the driver (39) on magnet plate (3) at same time engaging lock pin (41) in lock bushing (40).
22. Insert pivot stud (32) into drive gear (31) and driver (39). Line up marked teeth of release gears (34) and drive gear (31) and tighten pivot stud into magnet plate (3). Install drive spring (50) and reset spring (37). Check operation of manual release mechanism. Mount brake cover (See Paragraphs 2 to 6).
23. Alternate method of lining up release mechanism if markings not visible: Turn release gears (34) clockwise until both are tight and magnet gap is fully closed. Rotate release gears (34) counterclockwise from vertical centerline and center of brake 10 roots (valleys) of teeth. Drive gear (31) is to engage this tenth root the following number of teeth from top right and lower left edge of drive gear (31): 1 disc = 5, 2 disc = 6, 3 disc = 7, 4 disc = 8, and 5 disc = 9. Then continue per paragraph 23. Do not tamper with thermal release mechanism or control rod setting.

MAGNET COIL REPLACEMENT

(See Figures 2, 3 & 6 and Table 3)

24. Remove magnet assembly (3) (See Paragraphs 15 to 16).
25. Remove shading coils (51) (Single phase brakes only).
26. Coils (26) are held in place by epoxy cement or by bent over end laminations. Force coil off magnet if held by epoxy. Remove excess epoxy from magnet surfaces or bend up laminations and remove coils.
27. Replacement coils are held in place by bending of end laminations (See Figure 6). Insulating washers (27) are used above and below on replacements. Remember this when ordering replacement coils.
28. Replace coils. Sequence of black and yellow leads must be maintained (See Figure 3). Important: Shading coils must be replaced and held securely by staking in center of shading coil slot or by cementing with epoxy. Bend down end laminations to securely hold coils.
29. Reassemble brake (See Paragraphs 19 to 22).

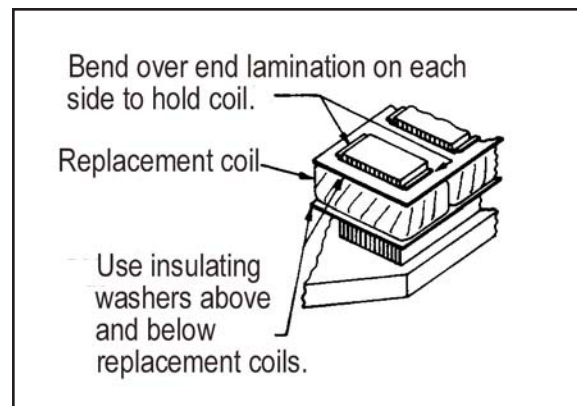

Figure 6. Fastening of Replacement Magnet Coils

TROUBLESHOOTING

BRAKE DOES NOT RELEASE

Check for failure of power supply to brake.
Check brake visually for broken or damaged parts.
Check for broken leadwire or bad electrical connection.
Check for correct voltage. Voltage must correspond to that listed on brake nameplate. If voltage is more than 10% below figure stamped on nameplate, magnet will not pull in, causing coil to burn out within minutes. If voltage is more than 10% above, coil will overheat and burn out.
Check for burned out coils (coils may be charred or burned).
Check for excessive magnet gap (See WEAR ADJUSTMENT).

BRAKE DOES NOT STOP

Check manual release. Drive gear must be turned completely clockwise.
Check thermal release. Release may have tripped.
Check brake visually for broken or damaged parts.
Check disc wear (See WEAR ADJUSTMENT).
Check for broken friction disc.
Make certain hub has not shifted position on shaft and that all rotating discs are fully engaged on hub.

BRAKE CHATTERS OR HUMS

Clean magnet faces if dirty. Insert a clean sheet of paper between magnet faces and energize brake. Move paper around between faces to dislodge dirt. Finally, remove paper.
Check that magnet faces are parallel in closed position. If not parallel along length of magnet, adjust (See WEAR ADJUSTMENT).
Check if shading coil is cracked, broken or out of position.
Check for low voltage. Magnet will not pull in and coil will burn out if voltage is more than 10% below figure stamped on nameplate.

SPECIFICATIONS

For NEMA Frames 213TC, 215TC, 254TC, and 256TC.
Adapters available for many other frames.

HEATERS: UL listed heaters available.

VOLTAGES: All standard NEMA 3 phase and single phase voltages and frequencies available. Other voltages and frequencies optional. Add suffix "S" to model number to denote single phase.

TORQUE: 10, 15, 25, 35, 50 and 75 lb. ft. available.

WARRANTY

Seller warrants products manufactured by it and supplied hereunder to be free from defects in materials and workmanship under normal use and proper maintenance for a period of twelve months from date of shipment. If within such period any such products shall be proved to Seller's reasonable satisfaction to be defective, such products shall be repaired or replaced at Seller's option Seller's obligation and Buyer's exclusive remedy hereunder shall be limited to such repair and replacement and shall be conditioned upon Seller's receiving written notice of any alleged defect no later than 10 days after its discovery within the warranty period and, at Seller's option, the return of such products to Seller, f.o.b. its factory, when such return is feasible. Seller reserves the right to satisfy its warranty obligation in full by reimbursing Buyer for all payments it makes hereunder, and Buyer shall thereupon return the products to Seller. Seller shall have the right to remedy such defects. Seller makes no warranty with respect to wear or use items, such as belts, chains, sprockets, discs and coils, all which are sold strictly AS IS.

The foregoing warranties are exclusive and in lieu of all other express and implied warranties (except of title) including but not limited to implied warranties of merchantability, fitness for a particular purpose, performance, or otherwise, and in no event shall the Seller be liable for claims (based upon breach of express or implied warranty, negligence, product liability, or otherwise) for any other damages, whether direct, immediate, incidental, foreseeable, consequential, or special.

ORDERING INFORMATION

The following information should be furnished with your order for:

REPLACEMENT PARTS

Brake Model Number
Part Number from Pages 2, 3, or 4.
Part Description from Pages 2, 3, or 4. (On hub order, bore diameter & keyway dimensions. On electrical parts, specify voltage, phase & frequency.)

REPLACEMENT BRAKE

Model Number
Voltage, Phase & Frequency
Hub Bore & Keyway Dimensions
Mounting - Horizontal or Vertical (If vertical, specify whether above or below motor. If brake includes foot mounting bracket or adapter, specify.)



DYNAMICS GROUP

4740 WEST ELECTRIC AVENUE • MILWAUKEE, WI 53219 • PHONE 414/672-7830 • FAX 414/672-5354 • www.dingsco.com